



PALADIN

CAST IRON RADIATORS



Montpellier
Height 790mm
Farrow & Ball – Bone
Belgravia Antique Brass TRV Valve Set
Antique Brass Pipe Sleeve Kit

Recapturing Yesterday for Today

PALADIN TAKES GREAT PRIDE IN BEING A PART OF THE RESURRECTION OF THIS OLD IRON ART FORM AND HAS TAKEN MUCH TIME TO FAITHFULLY REPRODUCE THE OLD ORIGINAL STYLES TO BRING BACK TO LIFE THE BEAUTY AND FORM OF THE ORIGINAL CAST IRON RADIATOR.

Not so long ago the cast iron radiator was a dinosaur of the past, carelessly discarded to the scrap yard and replaced with a modern flat radiator. Sadly many of the original beautiful cast iron radiators have been destroyed and our heritage was so nearly extinguished forever. As old original radiators became more and more rare they became increasingly expensive and therefore were only available to the few. Paladin has tried to faithfully reproduce the remaining beautiful pieces of functional art and market them at a price that is more widely affordable.

The development and mass production of cast iron radiators was an American phenomenon, the first patents dating back to 1841. Mr Joseph Nason who established the Nason Manufacturing Company in America in 1841 came to England and worked with Mr A M Perkins the inventor of the Perkins hot water system of heating.

Mr Nason and Mr Perkins directed foundries in London and elsewhere in Britain and together with Robert Briggs patented a steam radiator in 1862. Soon after this Nelson H Bundy in 1872 invented the Bundy Loop, a cast iron radiator design which played an important role in the evolution of the cast iron radiator as we know it today.

Until 1892 numerous American manufacturers produced a variety of designs and three principle manufacturers merged to form the American Radiator Company who also manufactured in Hull in the early 1900s where they manufactured radiators under The Ideal brand name. An interesting passage from The American Radiator Company's sales catalogue dated 1897 reads "the fact that our radiators are used in an increasing majority of the modern palatial office and public buildings and the better class of residences in this country inviting the most critical attention of the best heating engineers to every feature of their construction, is the highest possible endorsement of the excellence and superiority of our goods and eloquently testifies to the splendid results afforded by them".

Our Saint Paul radiator is a faithful copy of the original by the American Radiator Company and in their catalogue of 1897 it is described as "a work of art in iron".

Soon after the 1950s the cast iron radiator waned in popularity and the thin less bulky radiator, "paint it and disguise it", culture came along. However in the past few years the cast iron radiator has enjoyed a major revival in popularity and has become a desirable feature taking pride of place in living areas within both the period and modern home.

The Paladin Collection

THINK PALADIN, THINK NOSTALGIA. WE BLEND TRADITION WITH INNOVATION, CHARISMA, QUALITY AND CRAFTSMANSHIP TO MAKE A STUNNING SELECTION OF TRADITIONAL CAST IRON RADIATORS, DESIGNED TO ADD A DISTINCTIVE INDIVIDUAL BEAUTY TO ANY RESIDENCE, TRADITIONAL OR MODERN.

Paladin Radiators are a leading specialists in cast iron radiators that are custom built in our UK workshop for heat output and finish to suit your home. Our traditional style classic radiators have been plumbed into many unique homes across the world including Government House Nova Scotia Canada, the Tate Gallery and Somerset House London.

For more than two decades Paladin have created magnificent radiators for authenticity and superb detail, ideal for heating both traditional and contemporary buildings. Paladin offer competitive affordable prices and our experienced sales team are here to help with any enquiries you may have to help you make the right choice for your home.

01205 280354

sales@paladinradiators.com

www.paladinradiators.com





Radiators

Bartholomew	8
Churchill	10
Clarendon	12
Kensington	14
Montpellier	16
Neo Georgian	18
Oxford	22
Piccadilly	24
Pimlico	26
Saint Paul	28
Shaftsbury	30
Sloane	32
Victoriana	34
Electric	37

Colours & Finishes

Paladin Colours	38
Farrow & Ball	40
Premium Lacquers	43
Paint Effects	44
Colour Matching	48
Hand Polishing	49

Valves & Accessories

Valves & Fittings	50
Wall Stays	54
Air Vents	55
Pipe Sleeve Kits	56
Bush Ends	57

Technical Information

Data Sheets	59
Further Information	84



Piccadilly
Height 760 mm
Farrow & Ball – Drop Cloth
Kingsbury Polished Brass Manual Valve Set
Polished Brass Pipe Sleeve Kit

The Order Process

1. CHOOSE YOUR STYLE

Pick from our wide range of cast iron radiators, with a variety of styles and sizes to suit any property from Victorian terrace, to an ultra modern barn conversion. Guides and information on sizing are available at www.paladinradiators.com.

SEE PAGES 8 - 37

2. PICK YOUR FINISH

Choose from all of the wonderful finishing options available to you, this is always a personal thing and we hope we have something to suit all possible choices.

SEE PAGES 38 - 49

3. SELECT YOUR EXTRAS

Here you can choose Valves, Wall Stays, Air Vents and Pipe Sleeves to compliment your radiators and you are ready to go. Please do not hesitate to call us at any stage so we can help and assist you with your selections or any questions you may have.

SEE PAGES 50 - 57



Bartholomew

INSPIRED BY SIMPLICITY AND PRACTICALITY WE CREATED THIS
VERSATILE YET TIMELESS CLASSIC - THE BARTHOLOMEW

The Bartholomew is a timeless, classic cast iron radiator, whose design was originally used in hospitals in the Victorian era. The elegant, simple lines of the Bartholomew, named after the famous London hospital, lend themselves to suit both modern and period homes.

The simplicity of the Bartholomew enables many custom finish options, to transform the clean, smooth lines of this radiator into a delightfully stylish feature, for any room.



570 / 740 MM HEIGHTS

3-40 SECTIONS

10 YEAR GUARANTEE

For sizing and technical information see page 59



TO CHOOSE YOUR FINISH
AND ADD YOUR VALVES
& ACCESSORIES FROM
OUR EXTENSIVE RANGE
SEE PAGES 38 TO 57



Churchill

WHEN GOOD THINGS COME IN SMALL PACKAGES

The Churchill cast iron radiator is a perfectly recreated timeless classic. One of the most compact cast iron radiators in Paladin's range, the Churchill is ideally suited to add a touch of vintage charm to low bay windows, conservatories and loft conversions.

The Churchill may be one of the shortest of all the Paladin range, but at 117 Watts/398 BTUs per section, it is hugely heat efficient as well as adding timeless elegance to any room.

350 MM HEIGHT

3-40 SECTIONS

10 YEAR GUARANTEE

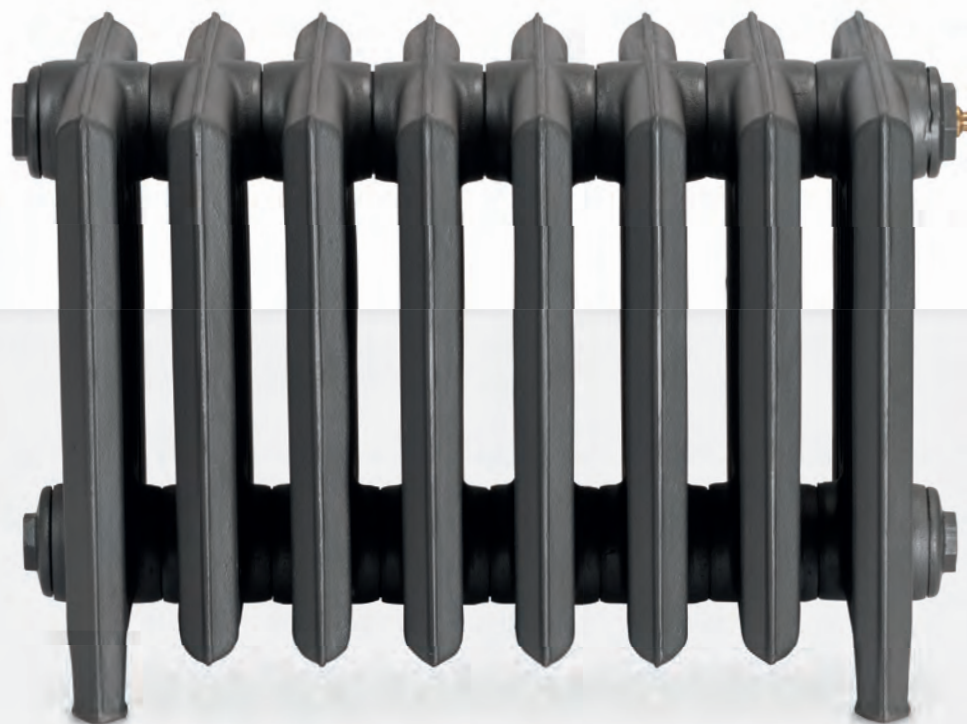

For sizing and technical information see page 60



TO CHOOSE YOUR FINISH
AND ADD YOUR VALVES
& ACCESSORIES FROM
OUR EXTENSIVE RANGE
SEE PAGES 38 TO 57



Clarendon

A TRULY CLASSIC DESIGN THAT HAS TAKEN INSPIRATION FROM SOME OF BRITAIN'S OLDEST AND MOST RENOWNED SCHOOLS

The Clarendon is an old school cast iron radiator which has been expertly designed to be an exact copy of the original Clarendon. It is named after the Clarendon group of old schools some of which include Harrow, Eton and Winchester. This modest and characterful radiator lends itself to both contemporary and traditional spaces.



440 / 740 MM HEIGHTS

3-40 SECTIONS

10 YEAR GUARANTEE

For sizing and technical information see page 61



TO CHOOSE YOUR FINISH
AND ADD YOUR VALVES
& ACCESSORIES FROM
OUR EXTENSIVE RANGE
SEE PAGES 38 TO 57



Kensington

WITH A FABULOUS FLUID FORM AND EXQUISITE ORNATE DETAIL,
THIS VINTAGE RADIATOR EXUDES LUXURY

The Kensington vintage cast iron radiator is a decoratively distinctive vintage styled cast iron radiator that echoes a bygone era. This freestanding vintage radiator has a stunning ornate scrolled detail that lends itself well to our hand-painted highlight option or an antique paint effect.

The Kensington is a popular choice for a traditional refurbishment, barn or warehouse conversion, but is equally at home in a modern setting. Let the beautiful lines of the Kensington magically enhance your room.



580 / 750 / 780 MM HEIGHTS

3-40 SECTIONS

10 YEAR GUARANTEE

For sizing and technical information see page 62



TO CHOOSE YOUR FINISH
AND ADD YOUR VALVES
& ACCESSORIES FROM
OUR EXTENSIVE RANGE
SEE PAGES 38 TO 57



Montpellier

INSPIRED BY THE DARING SIMPLICITY OF DAISIES TO BRING BEAUTY TO ANY ROOM

The Montpellier old style cast iron radiator, also known as the “daisy radiator”, is an alluring decorative style cast iron radiator. The Montpellier’s origins lie in France in the late 1890’s. The seductive design emits romance with its delicate daisy and ribbons pattern, which flows from the ornate foot of the radiator to the top.

The Montpellier lends itself well to a hand-painted highlight finish or a hand-polish effect, which only serves to accentuate and add more charm to this cast iron radiator – a genuinely captivating centrepiece for any room.

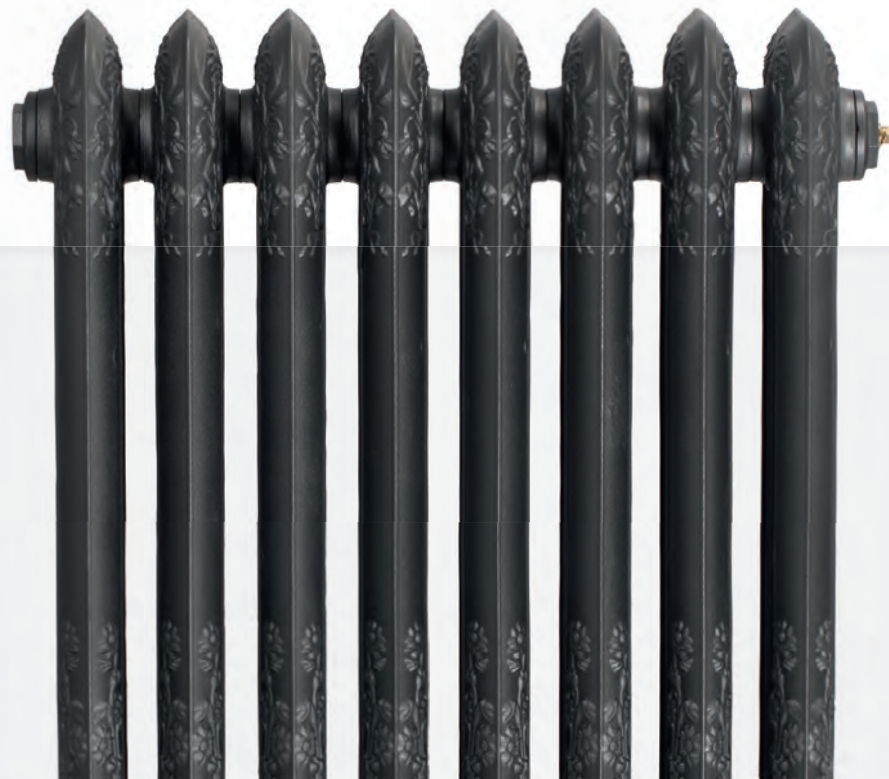

590 / 790 MM HEIGHTS

3-40 SECTIONS

10 YEAR GUARANTEE

For sizing and technical information see page 64



TO CHOOSE YOUR FINISH
AND ADD YOUR VALVES
& ACCESSORIES FROM
OUR EXTENSIVE RANGE
SEE PAGES 38 TO 57



Neo Georgian

"SIMPLICITY IS THE ULTIMATE SOPHISTICATION", LEONARDO DA VINCI

The stylish but straightforward Neo Georgian column cast iron radiator echoes back to the era of the early 1900s. The classic clean lines of this elegant design mean that it is well suited for either the modern or period home setting. With options of 2, 4 and even 6 column depths, the heat output per section is substantial.

With its clean and elegant design, The Neo Georgian column cast iron radiator is a popular choice for homes that were built during the Arts and Crafts era, which influenced Britain until the 1930s.



3-40 SECTIONS

10 YEAR GUARANTEE

2 Columns

490 / 640 / 740 / 1040 MM HEIGHTS

For sizing and technical information see page 65



Neo Georgian

4 Columns

360 / 505 / 660 / 760 / 960 MM HEIGHTS

For sizing and technical information see page 67



6 Columns

505 / 660 / 960 MM HEIGHTS

For sizing and technical information see page 70



Oxford

EMANATING FEELINGS OF LOVE AND ROMANCE, THE FRENCH-INSPIRED OXFORD RADIATES WARMTH, IN MORE WAYS THAN ONE

The opulent Oxford antique cast iron radiator has its origins in late 1800's France. This ornate, antique cast iron radiator boasts a smooth sweeping, scalloped top detail with an elaborate interwoven design at the feet.

This freestanding, extremely heat efficient antique radiator is perfect for a more extensive period room, barn or warehouse conversion, adding enchantment and delight in abundance.



470 / 570 / 765 MM HEIGHTS

3-40 SECTIONS

10 YEAR GUARANTEE

For sizing and technical information see page 72



TO CHOOSE YOUR FINISH
AND ADD YOUR VALVES
& ACCESSORIES FROM
OUR EXTENSIVE RANGE
SEE PAGES 38 TO 57



Piccadilly

A 19TH-CENTURY CELTIC MASTERPIECE THAT STIRS YOUR EMOTIONS AND OOZES INTRIGUE

The Piccadilly is a decorative cast iron radiator that flaunts flowing Celtic ribbons that are intertwined with leaves and crowned with scrolls. Originally manufactured by the American Radiator Company, circa 1880, this magnificent cast iron radiator is often found in churches, due to its distinctive and unusual Celtic design.

The Piccadilly cast iron radiator lends itself to our hand-painted highlight effect or our antiqued paint options. The Piccadilly is a stunning complement to both modern and period homes.



460 / 660 / 760 MM HEIGHTS

3-40 SECTIONS

10 YEAR GUARANTEE

For sizing and technical information see page 74



TO CHOOSE YOUR FINISH
AND ADD YOUR VALVES
& ACCESSORIES FROM
OUR EXTENSIVE RANGE
SEE PAGES 38 TO 57



Pimlico

ROYAL IN ITS ROOTS, SLIM AND ELEGANT IN ITS STYLE, MEET THE PIMLICO, A FAVOURITE OF THE EDWARDIANS

First produced in the late Victorian era, and popular in later Edwardian homes, the Pimlico cast iron radiator is also known as the "Duchess Radiator".

This slim line beauty is perfect for smaller rooms, having only 2 columns and a 100mm depth. The Pimlico is the perfect choice for a traditional cottage as well as a great choice for a modern day home.



460 / 660 / 760 MM HEIGHTS

3-40 SECTIONS

10 YEAR GUARANTEE

For sizing and technical information see page 76



TO CHOOSE YOUR FINISH
AND ADD YOUR VALVES
& ACCESSORIES FROM
OUR EXTENSIVE RANGE
SEE PAGES 38 TO 57



Saint Paul

DRAMATIC YET CHARISMATIC – MEET THE SAINT PAUL,
A WORK OF ART IN IRON

The Saint Paul cast iron radiator is a stunning example of skilled craftsmanship. Originally designed for the American Radiator Company, circa 1842, it was described as “a work of art in iron”. With an intricate ornate design of cherubs, dragons and lions intertwined with vines, this cast iron radiator generates feelings of wonderment.

The Saint Paul comes to life when choosing our antiqued or highlights paint effects and attracts even more attention with a hand polished finish. The Saint Paul is a genuinely unique and memorable masterpiece.

800 MM HEIGHT

3-40 SECTIONS

10 YEAR GUARANTEE



For sizing and technical information see page 77



TO CHOOSE YOUR FINISH
AND ADD YOUR VALVES
& ACCESSORIES FROM
OUR EXTENSIVE RANGE
SEE PAGES 38 TO 57



Shaftsbury

A BALLET INSPIRED BEAUTY, THE SHAFTSBURY PERFORMS ITS OWN SHOW WITH ITS GRACE AND ELEGANCE

The Shaftsbury cast iron radiator is a stunning example of ornate design and intricate detail. The swirls and waves of etched beauty make it the ideal cast iron radiator for an antiqued, hand-painted or polished finish.

The Shaftsbury originates from a London Ballet School, in the Victorian era, which gives rise to its delightful decadence. Distinctive and beautiful, the Shaftsbury cast iron radiator is the perfect choice for a traditional setting.



540 / 740 MM HEIGHTS

3-40 SECTIONS

10 YEAR GUARANTEE

For sizing and technical information see page 78



TO CHOOSE YOUR FINISH
AND ADD YOUR VALVES
& ACCESSORIES FROM
OUR EXTENSIVE RANGE
SEE PAGES 38 TO 57



Sloane

AN INTRICATE ELEGANT DESIGN, GOING BACK IN TIME

The Sloane cast iron radiator design was first produced in America in the 1880's. It is famous for its finely etched features which gives rise to its name of the curly eared princess.

The sophisticated design of the Sloane provides a contemporary look for the more modern setting as well as a traditional look for the period home.

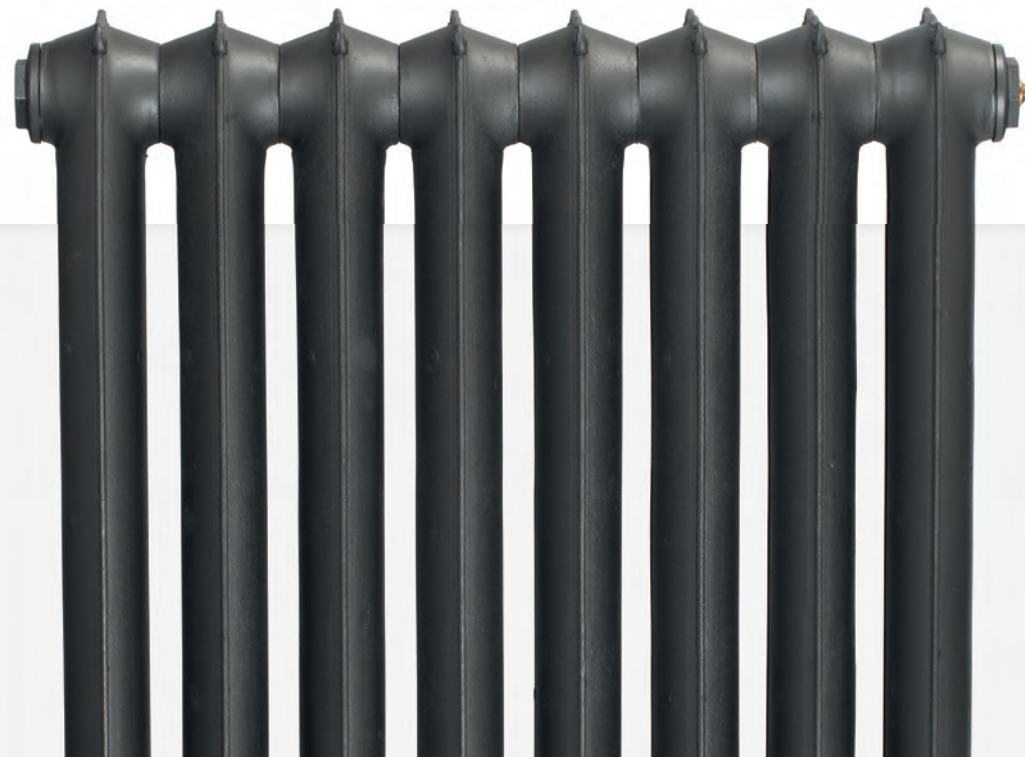

450 / 750 MM HEIGHTS

3-40 SECTIONS

10 YEAR GUARANTEE

For sizing and technical information see page 79



TO CHOOSE YOUR FINISH
AND ADD YOUR VALVES
& ACCESSORIES FROM
OUR EXTENSIVE RANGE
SEE PAGES 38 TO 57



Victoriana

WHEN HISTORY SHOULD REPEAT ITSELF, MEET THE VICTORIANA
– A 19TH CENTURY MASTERPIECE

The Victoriana design from 1880's Europe is a beautifully simplistic radiator range. The Victoriana design could be found in buildings during the late Victorian era. This simple, yet elegant style has been recreated by Paladin to offer an authentic, traditional cast iron radiator to suit both modern and period homes.



3-40 SECTIONS

10 YEAR GUARANTEE

3 Columns

450 / 645 / 745 MM HEIGHTS

For sizing and technical information see page 80



Victoriana

4 Columns

460 / 660 / 760 / 813 MM HEIGHTS

For sizing and technical information see page 82



Electric Cast Iron Radiators

EVEN WITH NO CENTRAL HEATING, YOU CAN BENEFIT FROM THE BEAUTY OF A CAST IRON RADIATOR

Paladin wants everyone to be able to own and enjoy a cast iron radiator, to be able to step back in time and appreciate the beauty of these magnificent centrepieces. An electric cast iron radiator is the ideal heating solution for areas where there is no standard central heating options and no other fuel supplies.

Combine a stylish, sophisticated look with the convenience of electrical operation
Our electric only operation cast iron radiators are fitted with a 240V single phase heating element which has thermostatically adjustable settings including a frost protection mode. We also have the option of a Radio Frequency controlled version (Home+ system) for single or multiple radiators which, when used with the fully programmable controller offers timed and temperature operation for your radiators.

Our electric radiators are supplied filled, tested and ready for wiring to a fused spur (standard lead length is 1200mm). Our electric cast iron radiators are available in a range of sizes. It is also possible to supply radiators with two elements (one at each end) when more significant outputs are required.

Please contact us to discuss the options available.



White

Satin

Chrome

Quartz

Gold

Steel

Textured Grey

Textured Dark Grey

Anthracite

Black



Cables are white as standard but on request black or light grey cable can be supplied.

Paladin Colours

STRIKING PAINTS FOR CAST IRON RADIATORS

Based on a range of metals the Paladin Colour palette is created to give you a truly classic look, using any one of the 10 unique Paladin Colours is popular way to achieve the look you want. Cast iron radiators do lend themselves to darker colours with the Natural Cast and Old Pewter finishes being amongst our most popular choices. The Copper and Gold's are also fine colour choices if you require rich and handsome colours to compliment your colour scheme. Whatever colour you choose the Paladin Colours have been carefully chosen and custom mixed just for Paladin they are hard wearing and washable and add a stunning metallic look to your cast iron radiators.

Our standard finish is Eggshell but we can also offer the whole range of finishes from matt to full gloss on request.





Anthracite Black



Natural Cast



Old Pewter



Pewter



Old Penny



Bronze



Aged Gold



Bright Gold



Sovereign Gold



Copper

It is important to note that it is not possible to truly recreate actual colours through electronic and printed media. We therefore cannot accept any responsibility for the accuracy of the colours shown throughout our website and those shown in our brochure. Swatches of the above Paladin ranges are available on request.

Farrow & Ball Colours

HISTORICAL AND AUTHENTIC PERIOD PAINT COLOURS TO ADD GRACE AND STYLE TO ANY ROOM



Paladin is proud to be an official partner and supplier of Farrow & Ball paints. Their stunning range of quality paints are a perfect match for any heritage property. They add a classic high quality finish to your radiator that perfectly complements almost any interior. Choose any colour from their extensive range for a long lasting superlative finish.



All White



Wevet



Wimbourne White



Pointing



James White



Clunch



White Tie



New White



Drop Cloth



House White



Matchstick



String



Cord



Shadow White



Shaded White



Tallow



Savage Ground



Salmon Drab



Dimity



Joa's White



Archive



Oxford Stone



Smoked Trout



London Stone



Slipper Satin



Lime White



Off White



Old White



Light Gray



Strong White



Ammonite



Cornforth White



Purbeck Stone



Worsted



Moles Breath



Stoney Ground



Bone



Cromarty



Mizzle



Blue Gray



Pidgeon



Blackened



Dimpse



Pavillion Gray



French Gray



Hardwick White



Lamp Room Gray



Skimming Stone



Elephants Breath



Dove Tail



Charleston Gray



London Clay



Brinjal



Great White



Pegnoir



Cinder Rose



Pink Ground



Setting Plaster



Dead Salmon



Middleton Pink



Calamine



Nancy's Blushes



Red Earth



Picture Gallery Red



Incarnadine



Rectory Red



Eating Room Red



Radicchio



Book Room Red



Charlottes Locks



Blazer



Pale Hound



Dayroom Yellow



Yellow Cake



Citron



Yellow Ground



Babouche



Ringwold Ground



Farrows Cream



Dorset Cream



Hay



Sudbury Yellow



India Yellow



Tunsgate Green



Green Ground



Cooking Apple Green



Ball Green



Card Room Green



Green Smoke



Churlish Green



Yeabridge Green



Breakfast Room Green



Calke Green



Arsenic



Studio Green



Vert De Tere



Lichen



Teresa's Green



Dix Blue



Vardo



Stone Blue



Cabbage White



Pavillion Blue



Pale Powder



Green Blue



Oval Room Blue



Inchyria Blue



Borrowed Light



Skylight



Light Blue



Parma Gray



Lulworth Blue



Cooks Blue



Blue Ground



St Giles Blue



Pitch Blue



Drawing Room Blue



Stiffkey Blue



Calluna



Pelt



Manor House Gray



Plummet



Downpipe



Hague Blue



Mahogany



Tanners Brown



Railings



Black Blue



Off Black



Pitch Black

Premium Lacquers

Now this is interesting, firstly we prepare and polish the radiator then it is coated with an opaque tinted lacquer that gives deep lustre that still shows the cast iron detail below. Premium Lacquers are available in a range of on trend colours for that more contemporary feel.



Sub-Lime

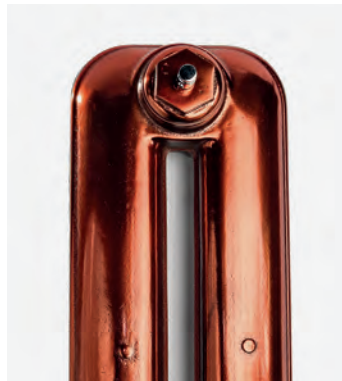

Candy Apple

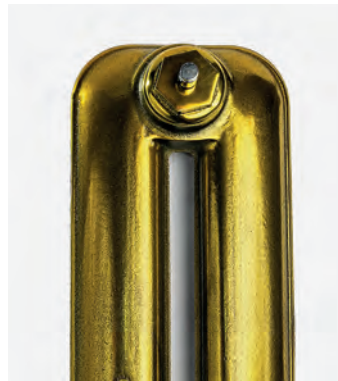

Sunburst



Carbon Smoke

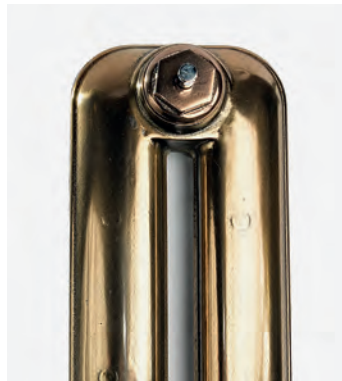

Rosie's Blushes

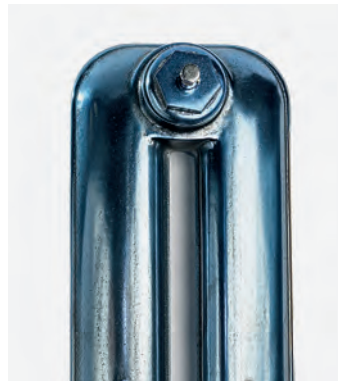

Arctic Blue



Paint Effects

ANTIQUED PAINT EFFECT

Step back in time with our antique finish paint effects

Why not enhance the delightful raised features of your ornate cast iron radiators with an Antiqued Paint Effect. Using a contrasting antiquing wash the details are given an authentic aged look picking out the details to transform your radiator into a real work of art.





Matchstick / Buff



Buff / Dauphin



London Stone / All White



Lead



Green



Pewter

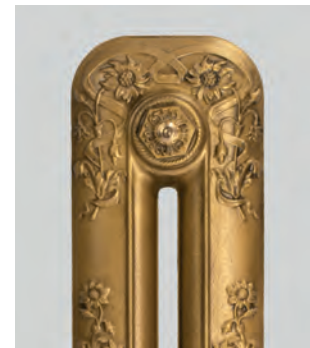

Bright Gold

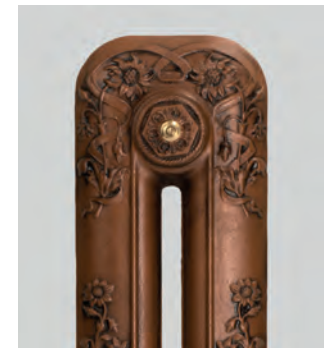

Copper



Aged Gold

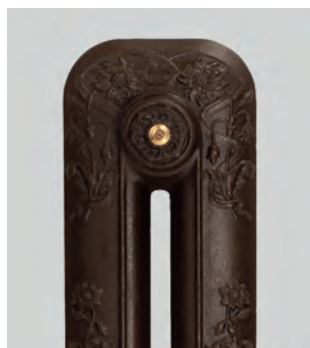

Old Penny



Old Pewter



Natural Cast

Paint Effects

HIGHLIGHT PAINT EFFECT

Unique hand-painted highlights to create dramatic eye-catching centrepieces in any room

The Highlight Paint Effect is a totally unique artisan effect that brings the detail of your radiators to life. Paladin have perfected this magnificent effect over the years to create stunning and individual cast iron radiators that become a fantastic eye catching centre piece in any room.

For a truly stunning and atmospheric result choose our Highlight Paint Effects where the beautiful moulded detail of every ornate cast iron radiator is gild paste highlighted by hand on top of the contrasting base colour in a choice of rich gold, striking pewter or warm copper.



Anthracite / Copper

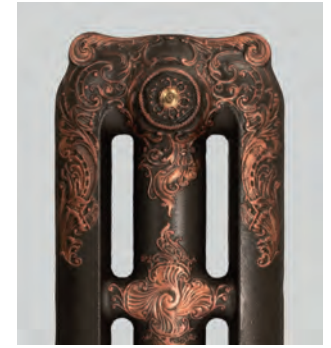

Natural Cast / Copper

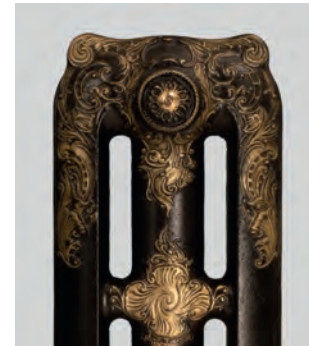

Anthracite / Gold



Natural Cast / Gold



Anthracite / Pewter



Natural Cast / Pewter

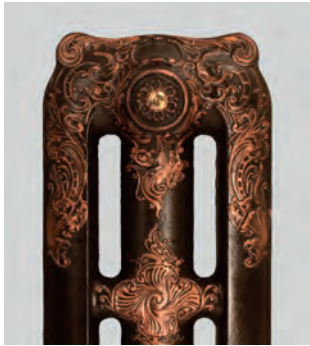

Old Pewter / Copper

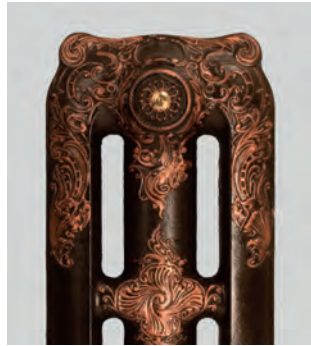

Old Penny / Copper

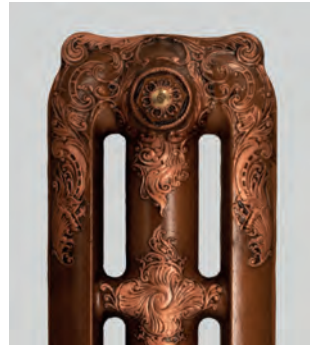

Antiqued Copper / Copper



Aged Gold / Copper

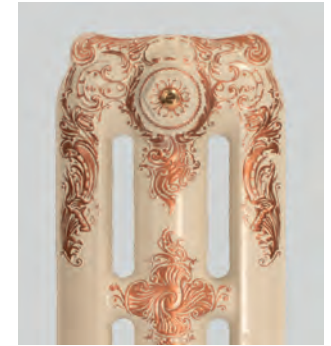

James White / Copper



Old Pewter / Gold

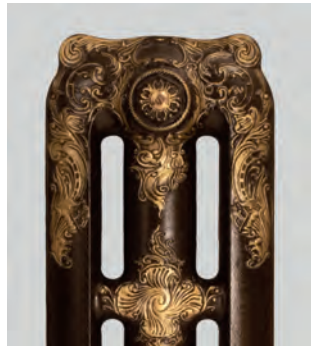

Old Penny / Gold

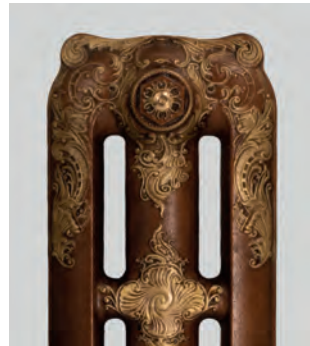

Antiqued Copper / Gold



Aged Gold / Gold

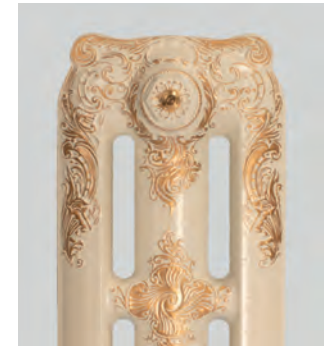

James White / Gold



Old Pewter / Pewter



Old Penny / Pewter

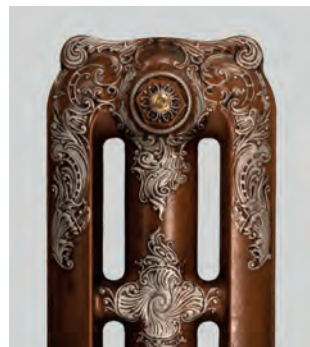

Antiqued Copper / Pewter

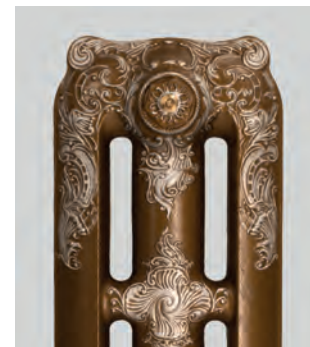

Aged Gold / Pewter



James White / Pewter

Colour Matching

CHOOSE A GREAT CUSTOM FINISH FOR YOUR CAST IRON RADIATORS

If you are looking for something different we are happy to offer our Colour Matching service where we have the facility to match almost any colour available. This includes the ever popular RAL colour ranges as well as BS colours or, if you have details of the colour you require, we can match it as closely as possible. You can also send us your colour swatches.

Our standard finish is an Eggshell but if you want a Full Gloss, Satin or even a Matt finish just let us know.



Hand Polishing

POLISHED PERFECTION, THE ULTIMATE FINISH

Polishing offers what can only be described as one of the best finishes you can buy. Hours of work go in to each section to create an amazing handsome finish that you will always be proud of. Using traditional methods, our skilled polishers work each section of your cast iron radiator to accentuate its beautiful unique detail.



Polished



Mirror



Satin



Burnished



Industrial



Valves & Fittings

CREATE YOUR PERFECT TEMPERATURE WITH OUR RANGE OF VALVES

Choose from our extensive range of manual or thermostatic radiator valves (TRV's). Our radiator valves are available in a comprehensive range of finishes including antique and burnished brass, brushed nickel, chrome, polished brass, black nickel, and antique copper.

THERMOSTATIC

Our thermostatic radiator valves come with an in-built temperature sensor which maintains the room at the temperature you have selected, helping you to save on heating costs.



BELGRAVIA



BELGRAVIA CORNER



Antique Brass



Antique Copper



Black Nickel



Brushed Brass



Brushed Nickel



Chrome



Antique Brass



Antique Copper



Black Nickel



Brushed Brass



Brushed Nickel



Chrome



Old English Brass



Old English Pewter



Polished Brass



Un-Lacquered Brass



Polished Nickel



Old English Brass



Old English Pewter



Polished Brass



Polished Nickel



Un-Lacquered Brass



CANTERBURY



Antique Brass



Antique Copper



Brushed Nickel



Colour Coded



BUCKINGHAM



Burnished Brass



Old English Pewter



HIGHGROVE



Antique Brass



Black Nickel



Brushed Nickel



Chrome



Old English Pewter



Polished Brass



BALMORAL



Antique Brass



Brushed Nickel



Chrome



Old English Pewter



GROSVENOR



Antique Brass



Antique Copper



Black Nickel



Brushed Nickel

"Fantastic product and the sales team were very helpful and friendly. The radiator is a stunning feature in our hall."

Jason Niamat 

Valves & Fittings

MANUAL

A manual radiator valve is operated by hand and can be set to allow less or more heated water to flow into the radiator. The amount of heat output will be constant regardless of the surrounding room temperature.



KINGSBURY



Antique Brass

Antique Copper

Black Nickel

Brushed Brass

Brushed Nickel

Chrome

Old English Brass

Old English Pewter

Polished Brass

Polished Nickel

Un-Lacquered Brass



KINGSBURY CORNER



Antique Brass

Antique Copper

Black Nickel

Brushed Brass

Brushed Nickel

Chrome

Old English Brass

Old English Pewter

Polished Brass

Polished Nickel

Un-Lacquered Brass



LAMBETH

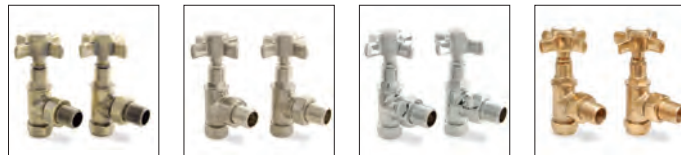

Antique Brass

Brushed Nickel

Chrome

Un-Lacquered Brass



BUCKINGHAM



Burnished Brass

Old English Pewter



CANTERBURY LEVER



Antique Brass



Antique Copper



Brushed Nickel



DAISY WHEEL



Antique Brass



Brushed Nickel



Old English Pewter



ETON



Brushed Nickel



Lacquered Brass



Polished Nickel



Un-Lacquered Brass



3/4" Un-Lacquered Brass



3/4" Chrome



CHELSEA



Antique Brass



Antique Copper



Black Nickel



Brushed Nickel



Chrome



SANDRINGHAM



Antique Brass



Brushed Nickel



Chrome



Old English Pewter

"Truly authentic and beautiful radiators, they transform a room dramatically. Excellent customer service, I would recommend Paladin to anyone."

Joanne Britton



Wall Stays

SUPPORT FOR YOUR RADIATOR, IN A RANGE OF STRIKING STYLES

Wall stays provide a firm brace to the wall for your cast iron radiator. All our cast iron radiators are floor standing and stable, however, due to their weight, we strongly recommend you tie your radiator to the wall with wall stays for added safety.

STANDARD RADIATOR WALL STAYS

Our standard wall stays are discreet and designed to be hidden at the back of your radiator. They are fixed to the wall and attached to the back of the radiator. Supplied in a galvanised finish as standard or they can be painted to match the colour of the radiator.

LUXURY BRASS RADIATOR WALL STAYS

These eye-catching and luxurious radiator wall stays add another matching feature to your cast iron radiator and is available in a wide choice of finishes to match your thermostatic or manual radiator valve choice.



Antique Brass

Antique Copper

Black Nickel

Brushed Brass



Brushed Nickel

Chrome

Old English Brass

Old English Pewter

Polished Brass

Polished Nickel

Un-Lacquered Brass

Air Vents

VENT VALVES ARE USED TO BLEED AIR FROM YOUR RADIATOR

All our cast iron radiators come with a brass bleed valve as standard. The Windsor bleed valves add an extra special touch to your cast iron radiator. They match our manual or thermostatic radiator valves as well as our custom finishes.

STANDARD

LUXURY



Antique Brass



Antique Copper



Black Nickel



Brushed Nickel



Chrome

Pipe Sleeve Kits

GET A STYLISH, SEAMLESS JOIN FROM FLOOR TO RADIATOR

Pipe sleeves and floor caps enable a smooth join from floor to radiator – a neat way to hide copper piping connections. As with our bush ends and valves, our pipe sleeves come in a range of stylish, decorative finishes.



Antique Brass



Antique Copper



Black Nickel



Brushed Brass



Brushed Nickel



Old English Brass



Old English Pewter



Polished Brass



Polished Chrome



Polished Nickel



Un-Lacquered Brass

DECORATIVE PIPE SLEEVE KITS

Our decorative radiator pipe sleeves and floor caps are especially designed to match perfectly with the Buckingham thermostatic radiator valve and the Buckingham manual radiator valve choice.



Burnished Brass



Graphite Grey

Bush Ends

ADD ORNATE BUSH ENDS FOR A LUXURIOUS FINISHING TOUCH TO YOUR RADIATOR

All our cast iron radiators come with standard cast iron bush ends.* However, if you want an opulent touch, add some of our unique ornate cast iron bush ends.**

STANDARD

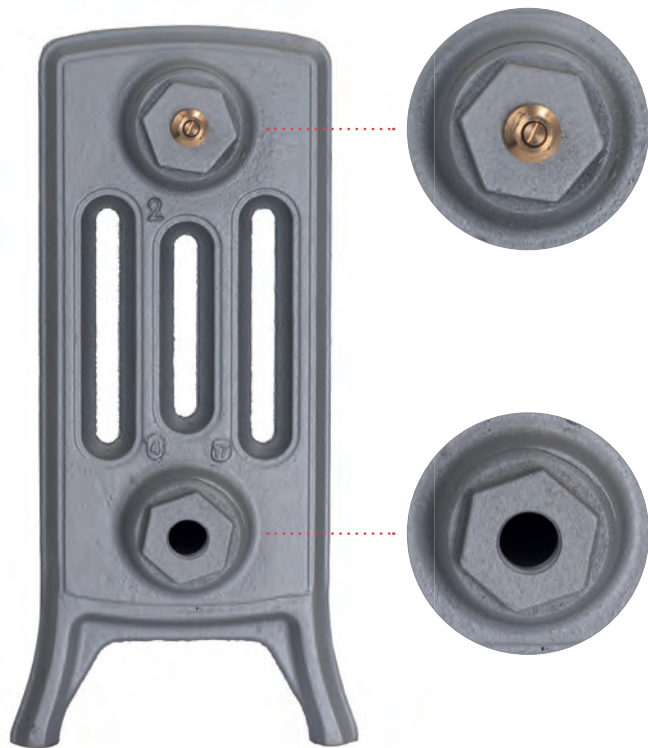

HAMPTON



*The Hampton ornate cast iron radiator bush ends come as standard on the Shaftsbury and Piccadilly cast iron radiators.
**Not available on the Neo Georgian range.



Oxford
Height 765 mm
Farrow & Ball – Stiffkey Blue
Belgravia Chrome TRV Valve Set
Chrome Pipe Sleeve Kit

570 mm

CODE/ SECTIONS	LENGTH	OUTPUT				WEIGHT (KG)	WATER CONTENT (LTRs)
		Dt60		Dt50			
		BTUs	WATTS	BTUs	WATTS		
BART-570-03	249	1115	327	880	258	21.12	5.10
BART-570-04	320	1487	436	1174	344	28.16	6.80
BART-570-05	392	1859	545	1467	430	35.20	8.50
BART-570-06	463	2231	654	1761	516	42.24	10.20
BART-570-07	535	2602	763	2054	602	49.28	11.90
BART-570-08	606	2974	872	2347	688	56.32	13.60
BART-570-09	678	3346	981	2641	774	63.36	15.30
BART-570-10	749	3718	1090	2934	860	70.40	17.00
BART-570-11	821	4090	1199	3228	946	77.44	18.70
BART-570-12	892	4461	1308	3521	1032	84.48	20.40
BART-570-13	964	4833	1417	3815	1118	91.52	22.10
BART-570-14	1035	5205	1525	4108	1204	98.56	23.80
BART-570-15	1107	5577	1634	4401	1290	105.60	25.50
BART-570-16	1178	5948	1743	4695	1376	112.64	27.20
BART-570-17	1250	6320	1852	4988	1462	119.68	28.90
BART-570-18	1321	6692	1961	5282	1548	126.72	30.60
BART-570-19	1393	7064	2070	5575	1634	133.76	32.30
BART-570-20	1464	7436	2179	5869	1720	140.80	34.00
BART-570-21	1536	7807	2288	6162	1806	147.84	35.70
BART-570-22	1607	8179	2397	6456	1892	154.88	37.40
BART-570-23	1679	8551	2506	6749	1978	161.92	39.10
BART-570-24	1750	8923	2615	7042	2064	168.96	40.80
BART-570-25	1822	9294	2724	7336	2150	176.00	42.50
BART-570-26	1893	9666	2833	7629	2236	183.04	44.20
BART-570-27	1965	10038	2942	7923	2322	190.08	45.90
BART-570-28	2036	10410	3051	8216	2408	197.12	47.60
BART-570-29	2108	10782	3160	8510	2494	204.16	49.30
BART-570-30	2179	11153	3269	8803	2580	211.20	51.00
BART-570-31	2251	11525	3378	9096	2666	218.24	52.70
BART-570-32	2322	11897	3487	9390	2752	225.28	54.40
BART-570-33	2394	12269	3596	9683	2838	232.32	56.10
BART-570-34	2465	12640	3705	9977	2924	239.36	57.80
BART-570-35	2537	13012	3814	10270	3010	246.40	59.50
BART-570-36	2608	13384	3923	10564	3096	253.44	61.20
BART-570-37	2680	13756	4032	10857	3182	260.48	62.90
BART-570-38	2751	14128	4141	11150	3268	267.52	64.60
BART-570-39	2823	14499	4250	11444	3354	274.56	66.30
BART-570-40	2894	14871	4358	11737	3440	281.60	68.00

740 mm

CODE/ SECTIONS	LENGTH	OUTPUT				WEIGHT (KG)	WATER CONTENT (LTRs)
		Dt60		Dt50			
		BTUs	WATTS	BTUs	WATTS		
BART-740-03	249	1443	423	1139	334	28.98	6.30
BART-740-04	320	1924	564	1519	445	38.64	8.40
BART-740-05	392	2405	705	1898	556	48.30	10.50
BART-740-06	463	2886	846	2278	668	57.96	12.60
BART-740-07	535	3367	987	2658	779	67.62	14.70
BART-740-08	606	3848	1128	3037	890	77.28	16.80
BART-740-09	678	4329	1269	3417	1001	86.94	18.90
BART-740-10	749	4810	1410	3797	1113	96.60	21.00
BART-740-11	821	5291	1551	4176	1224	106.26	23.10
BART-740-12	892	5772	1692	4556	1335	115.92	25.20
BART-740-13	964	6253	1833	4935	1447	125.58	27.30
BART-740-14	1035	6734	1974	5315	1558	135.24	29.40
BART-740-15	1107	7215	2115	5695	1669	144.90	31.50
BART-740-16	1178	7696	2256	6074	1780	154.56	33.60
BART-740-17	1250	8177	2397	6454	1892	164.22	35.70
BART-740-18	1321	8658	2538	6834	2003	173.88	37.80
BART-740-19	1393	9139	2679	7213	2114	183.54	39.90
BART-740-20	1464	9620	2820	7593	2225	193.20	42.00
BART-740-21	1536	10101	2961	7973	2337	202.86	44.10
BART-740-22	1607	10582	3102	8352	2448	212.52	46.20
BART-740-23	1679	11063	3243	8732	2559	222.18	48.30
BART-740-24	1750	11544	3383	9112	2670	231.84	50.40
BART-740-25	1822	12025	3524	9491	2782	241.50	52.50
BART-740-26	1893	12507	3665	9871	2893	251.16	54.60
BART-740-27	1965	12988	3806	10251	3004	260.82	56.70
BART-740-28	2036	13469	3947	10630	3116	270.48	58.80
BART-740-29	2108	13950	4088	11010	3227	280.14	60.90
BART-740-30	2179	14431	4229	11390	3338	289.80	63.00
BART-740-31	2251	14912	4370	11769	3449	299.46	65.10
BART-740-32	2322	15393	4511	12149	3561	309.12	67.20
BART-740-33	2394	15874	4652	12529	3672	318.78	69.30
BART-740-34	2465	16355	4793	12908	3783	328.44	71.40
BART-740-35	2537	16836	4934	13288	3894	338.10	73.50
BART-740-36	2608	17317	5075	13668	4006	347.76	75.60
BART-740-37	2680	17798	5216	14047	4117	357.42	77.70
BART-740-38	2751	18279	5357	14427	4228	367.08	79.80
BART-740-39	2823	18760	5498	14806	4340	376.74	81.90
BART-740-40	2894	19241	5639	15186	4451	386.40	84.00

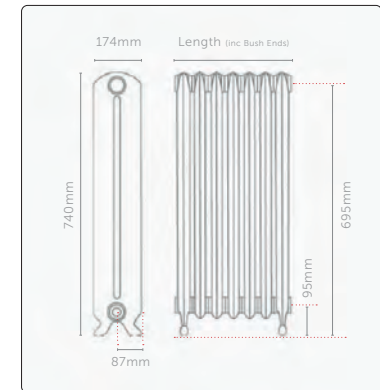
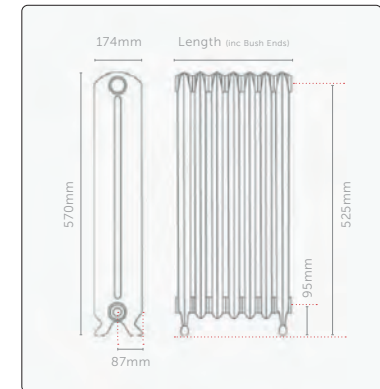

Dt50 figures shown in accordance with BS EN442. We have, from experience, found that the Dt60 figures usually give adequate output without oversizing the radiators on standard heating systems. Maximum test pressure = 3.3 bar | Maximum working pressure = 2.5 bar. Lengths quoted are given in good faith. However, due to the nature of the manufacturing process tolerances can and should be expected. Quoted dimensions should therefore only be used as a guideline. Longer lengths are available on request.

350mm

CODE/ SECTIONS	LENGTH	OUTPUT				WEIGHT (KG)	WATER CONTENT (LTRs)
		Dt60		Dt50			
		BTUs	WATTS	BTUs	WATTS		
CHUR-350-03	221	1440	422	1136	333	22	3.30
CHUR-350-04	283	1919	563	1515	444	29	4.40
CHUR-350-05	345	2399	703	1894	555	36	5.50
CHUR-350-06	407	2879	844	2272	666	43	6.60
CHUR-350-07	469	3359	984	2651	777	50	7.70
CHUR-350-08	532	3839	1125	3030	888	58	8.80
CHUR-350-09	594	4319	1266	3409	999	65	9.90
CHUR-350-10	656	4799	1406	3787	1110	72	11.00
CHUR-350-11	718	5278	1547	4166	1221	79	12.10
CHUR-350-12	780	5758	1688	4545	1332	86	13.20
CHUR-350-13	843	6238	1828	4924	1443	94	14.30
CHUR-350-14	905	6718	1969	5302	1554	101	15.40
CHUR-350-15	967	7198	2110	5681	1665	108	16.50
CHUR-350-16	1029	7678	2250	6060	1776	115	17.60
CHUR-350-17	1091	8158	2391	6438	1887	122	18.70
CHUR-350-18	1154	8637	2531	6817	1998	130	19.80
CHUR-350-19	1216	9117	2672	7196	2109	137	20.90
CHUR-350-20	1278	9597	2813	7575	2220	144	22.00
CHUR-350-21	1340	10077	2953	7953	2331	151	23.10
CHUR-350-22	1402	10557	3094	8332	2442	158	24.20
CHUR-350-23	1465	11037	3235	8711	2553	166	25.30
CHUR-350-24	1527	11516	3375	9090	2664	173	26.40
CHUR-350-25	1589	11996	3516	9468	2775	180	27.50
CHUR-350-26	1651	12476	3657	9847	2886	187	28.60
CHUR-350-27	1713	12956	3797	10226	2997	194	29.70
CHUR-350-28	1776	13436	3938	10604	3108	202	30.80
CHUR-350-29	1838	13916	4078	10983	3219	209	31.90
CHUR-350-30	1900	14396	4219	11362	3330	216	33.00
CHUR-350-31	1962	14875	4360	11741	3441	223	34.10
CHUR-350-32	2024	15355	4500	12119	3552	230	35.20
CHUR-350-33	2087	15835	4641	12498	3663	238	36.30
CHUR-350-34	2149	16315	4782	12877	3774	245	37.40
CHUR-350-35	2211	16795	4922	13256	3885	252	38.50
CHUR-350-36	2273	17275	5063	13634	3996	259	39.60
CHUR-350-37	2335	17755	5204	14013	4107	266	40.70
CHUR-350-38	2398	18234	5344	14392	4218	274	41.80
CHUR-350-39	2460	18714	5485	14771	4329	281	42.90
CHUR-350-40	2522	19194	5625	15149	4440	288	44.00

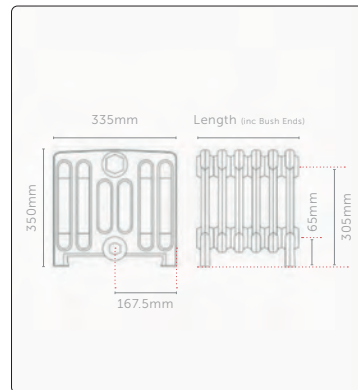

Dt50 figures shown in accordance with BS EN442. We have, from experience, found that the Dt60 figures usually give adequate output without oversizing the radiators on standard heating systems. Maximum test pressure = 3.3 bar | Maximum working pressure = 2.5 bar. Lengths quoted are given in good faith. However, due to the nature of the manufacturing process tolerances can and should be expected. Quoted dimensions should therefore only be used as a guideline. Longer lengths are available on request.

440 mm

CODE/ SECTIONS	LENGTH	OUTPUT				WEIGHT (KG)	WATER CONTENT (LTRs)
		Dt60		Dt50			
		BTUs	WATTS	BTUs	WATTS		
CLAR-440-03	228	645	189	509	149	13	3.00
CLAR-440-04	293	860	252	679	199	17	4.00
CLAR-440-05	358	1075	315	849	249	21	5.00
CLAR-440-06	423	1290	378	1018	299	25	6.00
CLAR-440-07	488	1505	441	1188	348	30	7.00
CLAR-440-08	552	1721	504	1358	398	34	8.00
CLAR-440-09	617	1936	567	1528	448	38	9.00
CLAR-440-10	682	2151	630	1697	498	42	10.00
CLAR-440-11	747	2366	693	1867	547	47	11.00
CLAR-440-12	812	2581	756	2037	597	51	12.00
CLAR-440-13	876	2796	819	2207	647	55	13.00
CLAR-440-14	941	3011	882	2376	697	59	14.00
CLAR-440-15	1006	3226	945	2546	746	64	15.00
CLAR-440-16	1071	3441	1009	2716	796	68	16.00
CLAR-440-17	1136	3656	1072	2886	846	72	17.00
CLAR-440-18	1200	3871	1135	3055	896	76	18.00
CLAR-440-19	1265	4086	1198	3225	945	81	19.00
CLAR-440-20	1330	4301	1261	3395	995	85	20.00
CLAR-440-21	1395	4516	1324	3565	1045	89	21.00
CLAR-440-22	1460	4732	1387	3734	1095	93	22.00
CLAR-440-23	1524	4947	1450	3904	1144	98	23.00
CLAR-440-24	1589	5162	1513	4074	1194	102	24.00
CLAR-440-25	1654	5377	1576	4244	1244	106	25.00
CLAR-440-26	1719	5592	1639	4413	1294	110	26.00
CLAR-440-27	1784	5807	1702	4583	1343	115	27.00
CLAR-440-28	1848	6022	1765	4753	1393	119	28.00
CLAR-440-29	1913	6237	1828	4923	1443	123	29.00
CLAR-440-30	1978	6452	1891	5092	1493	127	30.00
CLAR-440-31	2043	6667	1954	5262	1542	131	31.00
CLAR-440-32	2108	6882	2017	5432	1592	136	32.00
CLAR-440-33	2172	7097	2080	5602	1642	140	33.00
CLAR-440-34	2237	7312	2143	5771	1692	144	34.00
CLAR-440-35	2302	7527	2206	5941	1741	148	35.00
CLAR-440-36	2367	7743	2269	6111	1791	153	36.00
CLAR-440-37	2432	7958	2332	6281	1841	157	37.00
CLAR-440-38	2496	8173	2395	6450	1891	161	38.00
CLAR-440-39	2561	8388	2458	6620	1940	165	39.00
CLAR-440-40	2626	8603	2521	6790	1990	170	40.00

740 mm

CODE/ SECTIONS	LENGTH	OUTPUT				WEIGHT (KG)	WATER CONTENT (LTRs)
		Dt60		Dt50			
		BTUs	WATTS	BTUs	WATTS		
CLAR-740-03	3	1057	310	834	245	25	5.10
CLAR-740-04	4	1409	413	1112	326	34	6.80
CLAR-740-05	5	1762	516	1390	408	42	8.50
CLAR-740-06	6	2114	620	1668	489	51	10.20
CLAR-740-07	7	2466	723	1947	571	59	11.90
CLAR-740-08	8	2819	826	2225	652	68	13.60
CLAR-740-09	9	3171	929	2503	734	76	15.30
CLAR-740-10	10	3523	1033	2781	815	85	17.00
CLAR-740-11	11	3876	1136	3059	897	94	18.70
CLAR-740-12	12	4228	1239	3337	978	102	20.40
CLAR-740-13	13	4580	1342	3615	1060	110	22.10
CLAR-740-14	14	4933	1446	3893	1141	119	23.80
CLAR-740-15	15	5285	1549	4171	1223	127	25.50
CLAR-740-16	16	5637	1652	4449	1304	136	27.20
CLAR-740-17	17	5990	1755	4727	1386	144	28.90
CLAR-740-18	18	6342	1859	5005	1467	153	30.60
CLAR-740-19	19	6694	1962	5283	1549	161	32.30
CLAR-740-20	20	7046	2065	5562	1630	170	34.00
CLAR-740-21	21	7399	2168	5840	1712	178	35.70
CLAR-740-22	22	7751	2272	6118	1793	187	37.40
CLAR-740-23	23	8103	2375	6396	1875	195	39.10
CLAR-740-24	24	8456	2478	6674	1956	204	40.80
CLAR-740-25	25	8808	2582	6952	2038	212	42.50
CLAR-740-26	26	9160	2685	7230	2119	221	44.20
CLAR-740-27	27	9513	2788	7508	2201	229	45.90
CLAR-740-28	28	9865	2891	7786	2282	237	47.60
CLAR-740-29	29	10217	2995	8064	2364	246	49.30
CLAR-740-30	30	10570	3098	8342	2445	254	51.00
CLAR-740-31	31	10922	3201	8620	2527	263	52.70
CLAR-740-32	32	11274	3304	8898	2608	271	54.40
CLAR-740-33	33	11627	3408	9177	2690	280	56.10
CLAR-740-34	34	11979	3511	9455	2771	288	57.80
CLAR-740-35	35	12331	3614	9733	2853	297	59.50
CLAR-740-36	36	12684	3717	10011	2934	305	61.20
CLAR-740-37	37	13036	3821	10289	3016	314	62.90
CLAR-740-38	38	13388	3924	10567	3097	322	64.60
CLAR-740-39	39	13741	4027	10845	3179	331	66.30
CLAR-740-40	40	14093	4130	11123	3260	339	68.00

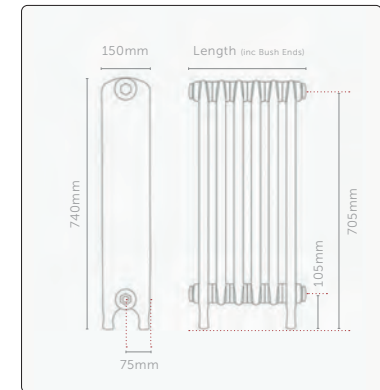
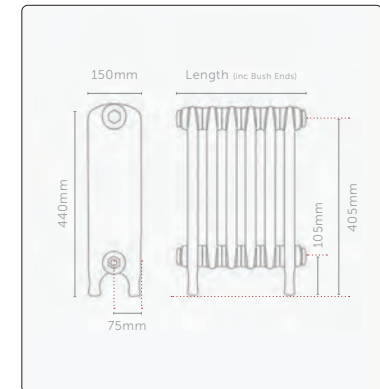

Dt50 figures shown in accordance with BS EN442. We have, from experience, found that the Dt60 figures usually give adequate output without oversizing the radiators on standard heating systems. Maximum test pressure = 3.3 bar | Maximum working pressure = 2.5 bar. Lengths quoted are given in good faith. However, due to the nature of the manufacturing process tolerances can and should be expected. Quoted dimensions should therefore only be used as a guideline. Longer lengths are available on request.

580 mm

CODE/ SECTIONS	LENGTH	OUTPUT				WEIGHT (KG)	WATER CONTENT (LTRs)
		Dt60		Dt50			
		BTUs	WATTS	BTUs	WATTS		
KEN-580-03	247	910	267	718	211	17	3.60
KEN-580-04	318	1214	356	958	281	23	4.80
KEN-580-05	389	1517	445	1197	351	29	6.00
KEN-580-06	460	1820	534	1437	421	34	7.20
KEN-580-07	531	2124	622	1676	491	40	8.40
KEN-580-08	602	2427	711	1916	561	46	9.60
KEN-580-09	673	2730	800	2155	632	51	10.80
KEN-580-10	744	3034	889	2395	702	57	12.00
KEN-580-11	815	3337	978	2634	772	63	13.20
KEN-580-12	886	3641	1067	2873	842	68	14.40
KEN-580-13	957	3944	1156	3113	912	74	15.60
KEN-580-14	1028	4247	1245	3352	983	80	16.80
KEN-580-15	1099	4551	1334	3592	1053	86	18.00
KEN-580-16	1170	4854	1423	3831	1123	91	19.20
KEN-580-17	1241	5158	1512	4071	1193	97	20.40
KEN-580-18	1312	5461	1601	4310	1263	103	21.60
KEN-580-19	1383	5764	1689	4550	1333	108	22.80
KEN-580-20	1454	6068	1778	4789	1404	114	24.00
KEN-580-21	1525	6371	1867	5029	1474	120	25.20
KEN-580-22	1596	6675	1956	5268	1544	125	26.40
KEN-580-23	1667	6978	2045	5507	1614	131	27.60
KEN-580-24	1738	7281	2134	5747	1684	137	28.80
KEN-580-25	1809	7585	2223	5986	1755	143	30.00
KEN-580-26	1880	7888	2312	6226	1825	148	31.20
KEN-580-27	1951	8191	2401	6465	1895	154	32.40
KEN-580-28	2022	8495	2490	6705	1965	160	33.60
KEN-580-29	2093	8798	2579	6944	2035	165	34.80
KEN-580-30	2164	9102	2668	7184	2105	171	36.00
KEN-580-31	2235	9405	2756	7423	2176	177	37.20
KEN-580-32	2306	9708	2845	7663	2246	182	38.40
KEN-580-33	2377	10012	2934	7902	2316	188	39.60
KEN-580-34	2448	10315	3023	8141	2386	194	40.80
KEN-580-35	2519	10619	3112	8381	2456	200	42.00
KEN-580-36	2590	10922	3201	8620	2526	205	43.20
KEN-580-37	2661	11225	3290	8860	2597	211	44.40
KEN-580-38	2732	11529	3379	9099	2667	217	45.60
KEN-580-39	2803	11832	3468	9339	2737	222	46.80
KEN-580-40	2874	12136	3557	9578	2807	228	48.00

750 mm

CODE/ SECTIONS	LENGTH	OUTPUT				WEIGHT (KG)	WATER CONTENT (LTRs)
		Dt60		Dt50			
		BTUs	WATTS	BTUs	WATTS		
KEN-750-03	247	1214	356	958	281	20	4.50
KEN-750-04	318	1619	475	1278	375	27	6.00
KEN-750-05	389	2024	593	1597	468	34	7.50
KEN-750-06	460	2429	712	1917	562	41	9.00
KEN-750-07	531	2834	830	2236	655	47	10.50
KEN-750-08	602	3238	949	2556	749	54	12.00
KEN-750-09	673	3643	1068	2875	843	61	13.50
KEN-750-10	744	4048	1186	3195	936	68	15.00
KEN-750-11	815	4453	1305	3514	1030	74	16.50
KEN-750-12	886	4858	1424	3834	1124	81	18.00
KEN-750-13	957	5262	1542	4153	1217	88	19.50
KEN-750-14	1028	5667	1661	4473	1311	95	21.00
KEN-750-15	1099	6072	1780	4792	1405	101	22.50
KEN-750-16	1170	6477	1898	5112	1498	108	24.00
KEN-750-17	1241	6882	2017	5431	1592	115	25.50
KEN-750-18	1312	7287	2136	5751	1686	122	27.00
KEN-750-19	1383	7691	2254	6070	1779	128	28.50
KEN-750-20	1454	8096	2373	6390	1873	135	30.00
KEN-750-21	1525	8501	2491	6709	1966	142	31.50
KEN-750-22	1596	8906	2610	7029	2060	149	33.00
KEN-750-23	1667	9311	2729	7348	2154	156	34.50
KEN-750-24	1738	9715	2847	7668	2247	162	36.00
KEN-750-25	1809	10120	2966	7987	2341	169	37.50
KEN-750-26	1880	10525	3085	8307	2435	176	39.00
KEN-750-27	1951	10930	3203	8626	2528	183	40.50
KEN-750-28	2022	11335	3322	8946	2622	189	42.00
KEN-750-29	2093	11739	3441	9265	2716	196	43.50
KEN-750-30	2164	12144	3559	9585	2809	203	45.00
KEN-750-31	2235	12549	3678	9904	2903	210	46.50
KEN-750-32	2306	12954	3797	10224	2996	216	48.00
KEN-750-33	2377	13359	3915	10543	3090	223	49.50
KEN-750-34	2448	13763	4034	10863	3184	230	51.00
KEN-750-35	2519	14168	4152	11182	3277	237	52.50
KEN-750-36	2590	14573	4271	11502	3371	243	54.00
KEN-750-37	2661	14978	4390	11821	3465	250	55.50
KEN-750-38	2732	15383	4508	12141	3558	257	57.00
KEN-750-39	2803	15787	4627	12460	3652	264	58.50
KEN-750-40	2874	16192	4746	12780	3746	270	60.00

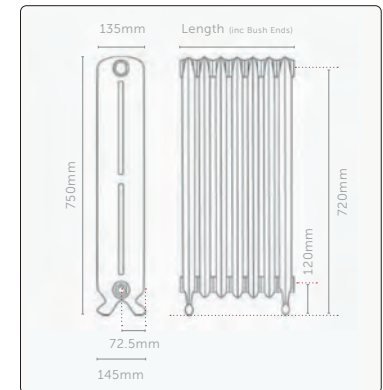
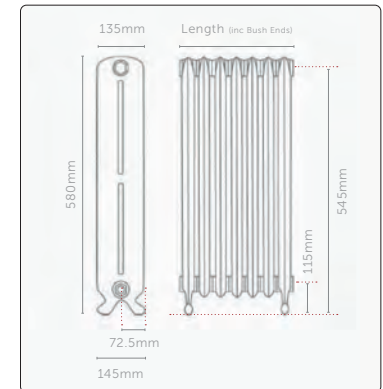

Dt50 figures shown in accordance with BS EN442. We have, from experience, found that the Dt60 figures usually give adequate output without oversizing the radiators on standard heating systems. Maximum test pressure = 3.3 bar | Maximum working pressure = 2.5 bar. Lengths quoted are given in good faith. However, due to the nature of the manufacturing process tolerances can and should be expected. Quoted dimensions should therefore only be used as a guideline. Longer lengths are available on request.

Technical Data – Kensington

780 mm

CODE/ SECTIONS	LENGTH	OUTPUT				WEIGHT (KG)	WATER CONTENT (LTRs)
		Dt60		Dt50			
		BTUs	WATTS	BTUs	WATTS		
KEN-780-03	247	1230	360	971	284	22	4.50
KEN-780-04	318	1640	481	1294	379	29	6.00
KEN-780-05	389	2050	601	1618	474	36	7.50
KEN-780-06	460	2459	721	1941	569	44	9.00
KEN-780-07	531	2869	841	2265	664	51	10.50
KEN-780-08	602	3279	961	2588	759	58	12.00
KEN-780-09	673	3689	1081	2912	853	65	13.50
KEN-780-10	744	4099	1201	3235	948	73	15.00
KEN-780-11	815	4509	1322	3559	1043	80	16.50
KEN-780-12	886	4919	1442	3882	1138	87	18.00
KEN-780-13	957	5329	1562	4206	1233	94	19.50
KEN-780-14	1028	5739	1682	4529	1327	102	21.00
KEN-780-15	1099	6149	1802	4853	1422	109	22.50
KEN-780-16	1170	6559	1922	5176	1517	116	24.00
KEN-780-17	1241	6968	2042	5500	1612	123	25.50
KEN-780-18	1312	7378	2162	5823	1707	131	27.00
KEN-780-19	1383	7788	2283	6147	1802	138	28.50
KEN-780-20	1454	8198	2403	6471	1896	145	30.00
KEN-780-21	1525	8608	2523	6794	1991	153	31.50
KEN-780-22	1596	9018	2643	7118	2086	160	33.00
KEN-780-23	1667	9428	2763	7441	2181	167	34.50
KEN-780-24	1738	9838	2883	7765	2276	174	36.00
KEN-780-25	1809	10248	3003	8088	2371	182	37.50
KEN-780-26	1880	10658	3124	8412	2465	189	39.00
KEN-780-27	1951	11067	3244	8735	2560	196	40.50
KEN-780-28	2022	11477	3364	9059	2655	203	42.00
KEN-780-29	2093	11887	3484	9382	2750	211	43.50
KEN-780-30	2164	12297	3604	9706	2845	218	45.00
KEN-780-31	2235	12707	3724	10029	2939	225	46.50
KEN-780-32	2306	13117	3844	10353	3034	232	48.00
KEN-780-33	2377	13527	3965	10676	3129	240	49.50
KEN-780-34	2448	13937	4085	11000	3224	247	51.00
KEN-780-35	2519	14347	4205	11323	3319	254	52.50
KEN-780-36	2590	14757	4325	11647	3414	261	54.00
KEN-780-37	2661	15167	4445	11970	3508	269	55.50
KEN-780-38	2732	15576	4565	12294	3603	276	57.00
KEN-780-39	2803	15986	4685	12618	3698	283	58.50
KEN-780-40	2874	16396	4805	12941	3793	290	60.00

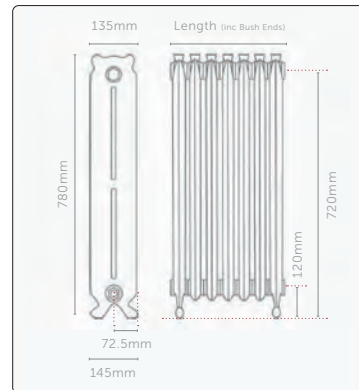

Dt50 figures shown in accordance with BS EN442. We have, from experience, found that the Dt60 figures usually give adequate output without oversizing the radiators on standard heating systems. Maximum test pressure = 3.3 bar | Maximum working pressure = 2.5 bar. Lengths quoted are given in good faith. However, due to the nature of the manufacturing process tolerances can and should be expected. Quoted dimensions should therefore only be used as a guideline. Longer lengths are available on request.

590 mm

CODE/ SECTIONS	LENGTH	OUTPUT				WEIGHT (KG)	WATER CONTENT (LTRs)
		Dt60		Dt50			
		BTUs	WATTS	BTUs	WATTS		
MONT-590-03	249	1094	321	864	253	24	4.50
MONT-590-04	320	1459	428	1151	337	32	6.00
MONT-590-05	392	1823	534	1439	422	40	7.50
MONT-590-06	464	2188	641	1727	506	49	9.00
MONT-590-07	535	2553	748	2015	591	57	10.50
MONT-590-08	607	2918	855	2303	675	65	12.00
MONT-590-09	678	3282	962	2591	759	73	13.50
MONT-590-10	750	3647	1069	2878	844	81	15.00
MONT-590-11	822	4012	1176	3166	928	89	16.50
MONT-590-12	893	4376	1283	3454	1012	97	18.00
MONT-590-13	965	4741	1389	3742	1097	105	19.50
MONT-590-14	1036	5106	1496	4030	1181	113	21.00
MONT-590-15	1108	5470	1603	4318	1265	121	22.50
MONT-590-16	1180	5835	1710	4605	1350	129	24.00
MONT-590-17	1251	6200	1817	4893	1434	137	25.50
MONT-590-18	1323	6564	1924	5181	1518	145	27.00
MONT-590-19	1394	6929	2031	5469	1603	154	28.50
MONT-590-20	1466	7294	2138	5757	1687	162	30.00
MONT-590-21	1538	7658	2245	6045	1772	170	31.50
MONT-590-22	1609	8023	2351	6332	1856	178	33.00
MONT-590-23	1681	8388	2458	6620	1940	186	34.50
MONT-590-24	1752	8753	2565	6908	2025	194	36.00
MONT-590-25	1824	9117	2672	7196	2109	202	37.50
MONT-590-26	1896	9482	2779	7484	2193	210	39.00
MONT-590-27	1967	9847	2886	7772	2278	218	40.50
MONT-590-28	2039	10211	2993	8059	2362	226	42.00
MONT-590-29	2110	10576	3100	8347	2446	234	43.50
MONT-590-30	2182	10941	3207	8635	2531	242	45.00
MONT-590-31	2254	11305	3313	8923	2615	251	46.50
MONT-590-32	2325	11670	3420	9211	2700	259	48.00
MONT-590-33	2397	12035	3527	9499	2784	267	49.50
MONT-590-34	2468	12399	3634	9786	2868	275	51.00
MONT-590-35	2540	12764	3741	10074	2953	283	52.50
MONT-590-36	2612	13129	3848	10362	3037	291	54.00
MONT-590-37	2683	13493	3955	10650	3121	299	55.50
MONT-590-38	2755	13858	4062	10938	3206	307	57.00
MONT-590-39	2826	14223	4168	11226	3290	315	58.50
MONT-590-40	2898	14588	4275	11513	3374	323	60.00

790 mm

CODE/ SECTIONS	LENGTH	OUTPUT				WEIGHT (KG)	WATER CONTENT (LTRs)
		Dt60		Dt50			
		BTUs	WATTS	BTUs	WATTS		
MONT-790-03	247	1469	431	1159	340	32	6.30
MONT-790-04	318	1959	574	1546	453	43	8.40
MONT-790-05	389	2448	718	1932	566	53	10.50
MONT-790-06	460	2938	861	2319	680	64	12.60
MONT-790-07	531	3428	1005	2705	793	75	14.70
MONT-790-08	602	3917	1148	3092	906	85	16.80
MONT-790-09	673	4407	1292	3478	1019	96	18.90
MONT-790-10	744	4897	1435	3865	1133	106	21.00
MONT-790-11	815	5386	1579	4251	1246	117	23.10
MONT-790-12	886	5876	1722	4638	1359	128	25.20
MONT-790-13	957	6366	1866	5024	1473	138	27.30
MONT-790-14	1028	6855	2009	5411	1586	149	29.40
MONT-790-15	1099	7345	2153	5797	1699	160	31.50
MONT-790-16	1170	7835	2296	6184	1812	170	33.60
MONT-790-17	1241	8324	2440	6570	1926	181	35.70
MONT-790-18	1312	8814	2583	6957	2039	192	37.80
MONT-790-19	1383	9304	2727	7343	2152	202	39.90
MONT-790-20	1454	9793	2870	7730	2265	213	42.00
MONT-790-21	1525	10283	3014	8116	2379	223	44.10
MONT-790-22	1596	10773	3157	8502	2492	234	46.20
MONT-790-23	1667	11262	3301	8889	2605	245	48.30
MONT-790-24	1738	11752	3444	9275	2718	255	50.40
MONT-790-25	1809	12242	3588	9662	2832	266	52.50
MONT-790-26	1880	12731	3731	10048	2945	277	54.60
MONT-790-27	1951	13221	3875	10435	3058	287	56.70
MONT-790-28	2022	13711	4018	10821	3172	298	58.80
MONT-790-29	2093	14200	4162	11208	3285	309	60.90
MONT-790-30	2164	14690	4305	11594	3398	319	63.00
MONT-790-31	2235	15180	4449	11981	3511	330	65.10
MONT-790-32	2306	15669	4592	12367	3625	341	67.20
MONT-790-33	2377	16159	4736	12754	3738	351	69.30
MONT-790-34	2448	16649	4879	13140	3851	362	71.40
MONT-790-35	2519	17138	5023	13527	3964	372	73.50
MONT-790-36	2590	17628	5166	13913	4078	383	75.60
MONT-790-37	2661	18118	5310	14300	4191	394	77.70
MONT-790-38	2732	18607	5453	14686	4304	404	79.80
MONT-790-39	2803	19097	5597	15073	4418	415	81.90
MONT-790-40	2874	19587	5741	15459	4531	426	84.00

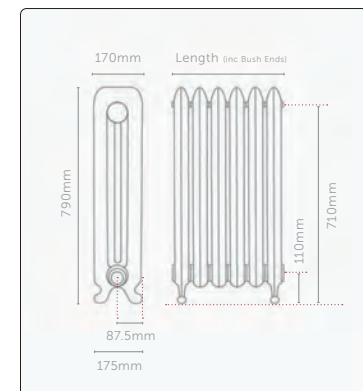
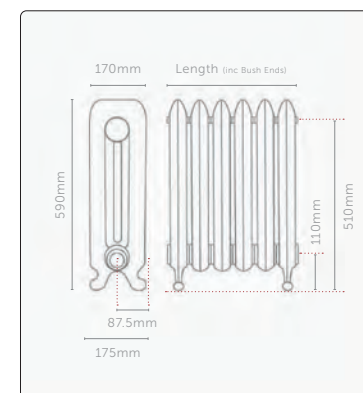

Dt50 figures shown in accordance with BS EN442. We have, from experience, found that the Dt60 figures usually give adequate output without oversizing the radiators on standard heating systems. Maximum test pressure = 3.3 bar | Maximum working pressure = 2.5 bar. Lengths quoted are given in good faith. However, due to the nature of the manufacturing process tolerances can and should be expected. Quoted dimensions should therefore only be used as a guideline. Longer lengths are available on request.

Technical Data – Neo Georgian 2 column

See Page 18

490 mm

CODE/ SECTIONS	LENGTH	OUTPUT				WEIGHT (KG)	WATER CONTENT (LTRs)
		Dt60		Dt50			
		BTUs	WATTS	BTUs	WATTS		
GEO2-490-03	208	532	156	420	123	8	1.08
GEO2-490-04	269	709	208	560	164	10	1.44
GEO2-490-05	330	886	260	699	205	13	1.80
GEO2-490-06	391	1063	312	839	246	16	2.16
GEO2-490-07	452	1241	364	979	287	18	2.52
GEO2-490-08	512	1418	416	1119	328	21	2.88
GEO2-490-09	573	1595	468	1259	369	23	3.24
GEO2-490-10	634	1772	519	1399	410	26	3.60
GEO2-490-11	695	1950	571	1539	451	29	3.96
GEO2-490-12	756	2127	623	1679	492	31	4.32
GEO2-490-13	816	2304	675	1819	533	34	4.68
GEO2-490-14	877	2481	727	1958	574	36	5.04
GEO2-490-15	938	2659	779	2098	615	39	5.40
GEO2-490-16	999	2836	831	2238	656	42	5.76
GEO2-490-17	1060	3013	883	2378	697	44	6.12
GEO2-490-18	1120	3190	935	2518	738	47	6.48
GEO2-490-19	1181	3368	987	2658	779	49	6.84
GEO2-490-20	1242	3545	1039	2798	820	52	7.20
GEO2-490-21	1303	3722	1091	2938	861	55	7.56
GEO2-490-22	1364	3899	1143	3078	902	57	7.92
GEO2-490-23	1424	4077	1195	3218	943	60	8.28
GEO2-490-24	1485	4254	1247	3357	984	62	8.64
GEO2-490-25	1546	4431	1299	3497	1025	65	9.00
GEO2-490-26	1607	4608	1351	3637	1066	68	9.36
GEO2-490-27	1668	4786	1403	3777	1107	70	9.72
GEO2-490-28	1728	4963	1455	3917	1148	73	10.08
GEO2-490-29	1789	5140	1506	4057	1189	75	10.44
GEO2-490-30	1850	5317	1558	4197	1230	78	10.80
GEO2-490-31	1911	5495	1610	4337	1271	81	11.16
GEO2-490-32	1972	5672	1662	4477	1312	83	11.52
GEO2-490-33	2032	5849	1714	4616	1353	86	11.88
GEO2-490-34	2093	6026	1766	4756	1394	88	12.24
GEO2-490-35	2154	6204	1818	4896	1435	91	12.60
GEO2-490-36	2215	6381	1870	5036	1476	94	12.96
GEO2-490-37	2276	6558	1922	5176	1517	96	13.32
GEO2-490-38	2336	6735	1974	5316	1558	99	13.68
GEO2-490-39	2397	6912	2026	5456	1599	101	14.04
GEO2-490-40	2458	7090	2078	5596	1640	104	14.40

640 mm

CODE/ SECTIONS	LENGTH	OUTPUT				WEIGHT (KG)	WATER CONTENT (LTRs)
		Dt60		Dt50			
		BTUs	WATTS	BTUs	WATTS		
GEO2-640-03	208	597	175	471	138	10	1.44
GEO2-640-04	269	795	233	628	184	14	1.92
GEO2-640-05	330	994	291	785	230	17	2.40
GEO2-640-06	391	1193	350	942	276	21	2.88
GEO2-640-07	452	1392	408	1099	322	24	3.36
GEO2-640-08	512	1591	466	1256	368	27	3.84
GEO2-640-09	573	1790	525	1413	414	31	4.32
GEO2-640-10	634	1989	583	1570	460	34	4.80
GEO2-640-11	695	2187	641	1726	506	38	5.28
GEO2-640-12	756	2386	699	1883	552	41	5.76
GEO2-640-13	816	2585	758	2040	598	44	6.24
GEO2-640-14	877	2784	816	2197	644	48	6.72
GEO2-640-15	938	2983	874	2354	690	51	7.20
GEO2-640-16	999	3182	933	2511	736	55	7.68
GEO2-640-17	1060	3381	991	2668	782	58	8.16
GEO2-640-18	1120	3579	1049	2825	828	61	8.64
GEO2-640-19	1181	3778	1107	2982	874	65	9.12
GEO2-640-20	1242	3977	1166	3139	920	68	9.60
GEO2-640-21	1303	4176	1224	3296	966	72	10.08
GEO2-640-22	1364	4375	1282	3453	1012	75	10.56
GEO2-640-23	1424	4574	1340	3610	1058	78	11.04
GEO2-640-24	1485	4773	1399	3767	1104	82	11.52
GEO2-640-25	1546	4971	1457	3924	1150	85	12.00
GEO2-640-26	1607	5170	1515	4081	1196	89	12.48
GEO2-640-27	1668	5369	1574	4238	1242	92	12.96
GEO2-640-28	1728	5568	1632	4395	1288	96	13.44
GEO2-640-29	1789	5767	1690	4552	1334	99	13.92
GEO2-640-30	1850	5966	1748	4709	1380	102	14.40
GEO2-640-31	1911	6165	1807	4866	1426	106	14.88
GEO2-640-32	1972	6363	1865	5022	1472	109	15.36
GEO2-640-33	2032	6562	1923	5179	1518	113	15.84
GEO2-640-34	2093	6761	1982	5336	1564	116	16.32
GEO2-640-35	2154	6960	2040	5493	1610	119	16.80
GEO2-640-36	2215	7159	2098	5650	1656	123	17.28
GEO2-640-37	2276	7358	2156	5807	1702	126	17.76
GEO2-640-38	2336	7557	2215	5964	1748	130	18.24
GEO2-640-39	2397	7755	2273	6121	1794	133	18.72
GEO2-640-40	2458	7954	2331	6278	1840	136	19.20

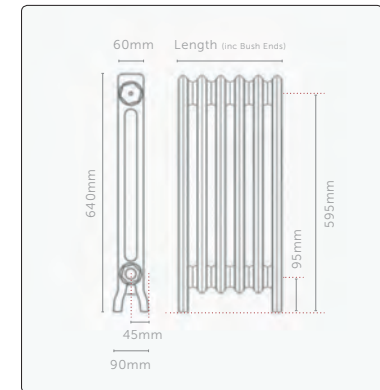
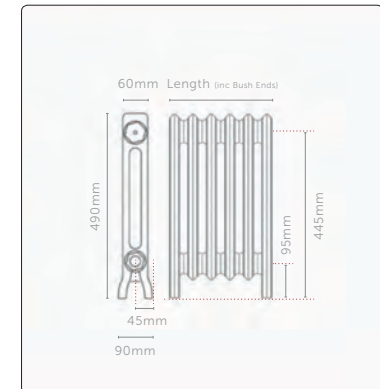

Dt50 figures shown in accordance with BS EN442. We have, from experience, found that the Dt60 figures usually give adequate output without oversizing the radiators on standard heating systems. Maximum test pressure = 3.3 bar | Maximum working pressure = 2.5 bar. Lengths quoted are given in good faith. However, due to the nature of the manufacturing process tolerances can and should be expected. Quoted dimensions should therefore only be used as a guideline. Longer lengths are available on request.

Technical Data – Neo Georgian 2 column

740 mm

CODE/ SECTIONS	LENGTH	OUTPUT				WEIGHT (KG)	WATER CONTENT (LTRs)
		Dt60		Dt50			
		BTUs	WATTS	BTUs	WATTS		
GEO2-740-03	208	804	236	635	186	12	1.68
GEO2-740-04	269	1072	314	846	248	15	2.24
GEO2-740-05	330	1340	393	1058	310	19	2.80
GEO2-740-06	391	1608	471	1269	372	23	3.36
GEO2-740-07	452	1876	550	1481	434	27	3.92
GEO2-740-08	512	2144	628	1692	496	31	4.48
GEO2-740-09	573	2412	707	1904	558	34	5.04
GEO2-740-10	634	2680	786	2115	620	38	5.60
GEO2-740-11	695	2948	864	2327	682	42	6.16
GEO2-740-12	756	3216	943	2539	744	46	6.72
GEO2-740-13	816	3484	1021	2750	806	50	7.28
GEO2-740-14	877	3752	1100	2962	868	54	7.84
GEO2-740-15	938	4020	1178	3173	930	57	8.40
GEO2-740-16	999	4288	1257	3385	992	61	8.96
GEO2-740-17	1060	4556	1335	3596	1054	65	9.52
GEO2-740-18	1120	4824	1414	3808	1116	69	10.08
GEO2-740-19	1181	5092	1493	4019	1178	73	10.64
GEO2-740-20	1242	5361	1571	4231	1240	76	11.20
GEO2-740-21	1303	5629	1650	4442	1302	80	11.76
GEO2-740-22	1364	5897	1728	4654	1364	84	12.32
GEO2-740-23	1424	6165	1807	4866	1426	88	12.88
GEO2-740-24	1485	6433	1885	5077	1488	92	13.44
GEO2-740-25	1546	6701	1964	5289	1550	96	14.00
GEO2-740-26	1607	6969	2042	5500	1612	99	14.56
GEO2-740-27	1668	7237	2121	5712	1674	103	15.12
GEO2-740-28	1728	7505	2200	5923	1736	107	15.68
GEO2-740-29	1789	7773	2278	6135	1798	111	16.24
GEO2-740-30	1850	8041	2357	6346	1860	115	16.80
GEO2-740-31	1911	8309	2435	6558	1922	118	17.36
GEO2-740-32	1972	8577	2514	6769	1984	122	17.92
GEO2-740-33	2032	8845	2592	6981	2046	126	18.48
GEO2-740-34	2093	9113	2671	7192	2108	130	19.04
GEO2-740-35	2154	9381	2749	7404	2170	134	19.60
GEO2-740-36	2215	9649	2828	7616	2232	138	20.16
GEO2-740-37	2276	9917	2906	7827	2294	141	20.72
GEO2-740-38	2336	10185	2985	8039	2356	145	21.28
GEO2-740-39	2397	10453	3064	8250	2418	149	21.84
GEO2-740-40	2458	10721	3142	8462	2480	153	22.40

1040 mm

CODE/ SECTIONS	LENGTH	OUTPUT				WEIGHT (KG)	WATER CONTENT (LTRs)
		Dt60		Dt50			
		BTUs	WATTS	BTUs	WATTS		
GEO2-1040-03	208	960	281	757	222	16	2.40
GEO2-1040-04	269	1280	375	1010	296	21	3.20
GEO2-1040-05	330	1600	469	1262	370	26	4.00
GEO2-1040-06	391	1919	563	1515	444	31	4.80
GEO2-1040-07	452	2239	656	1767	518	36	5.60
GEO2-1040-08	512	2559	750	2020	592	41	6.40
GEO2-1040-09	573	2879	844	2272	666	46	7.20
GEO2-1040-10	634	3199	938	2525	740	52	8.00
GEO2-1040-11	695	3519	1031	2777	814	57	8.80
GEO2-1040-12	756	3839	1125	3030	888	62	9.60
GEO2-1040-13	816	4159	1219	3282	962	67	10.40
GEO2-1040-14	877	4479	1313	3535	1036	72	11.20
GEO2-1040-15	938	4799	1406	3787	1110	77	12.00
GEO2-1040-16	999	5118	1500	4040	1184	82	12.80
GEO2-1040-17	1060	5438	1594	4292	1258	88	13.60
GEO2-1040-18	1120	5758	1688	4545	1332	93	14.40
GEO2-1040-19	1181	6078	1781	4797	1406	98	15.20
GEO2-1040-20	1242	6398	1875	5050	1480	103	16.00
GEO2-1040-21	1303	6718	1969	5302	1554	108	16.80
GEO2-1040-22	1364	7038	2063	5555	1628	113	17.60
GEO2-1040-23	1424	7358	2156	5807	1702	119	18.40
GEO2-1040-24	1485	7678	2250	6060	1776	124	19.20
GEO2-1040-25	1546	7998	2344	6312	1850	129	20.00
GEO2-1040-26	1607	8317	2438	6565	1924	134	20.80
GEO2-1040-27	1668	8637	2531	6817	1998	139	21.60
GEO2-1040-28	1728	8957	2625	7070	2072	144	22.40
GEO2-1040-29	1789	9277	2719	7322	2146	149	23.20
GEO2-1040-30	1850	9597	2813	7575	2220	155	24.00
GEO2-1040-31	1911	9917	2906	7827	2294	160	24.80
GEO2-1040-32	1972	10237	3000	8080	2368	165	25.60
GEO2-1040-33	2032	10557	3094	8332	2442	170	26.40
GEO2-1040-34	2093	10877	3188	8585	2516	175	27.20
GEO2-1040-35	2154	11197	3282	8837	2590	180	28.00
GEO2-1040-36	2215	11516	3375	9090	2664	185	28.80
GEO2-1040-37	2276	11836	3469	9342	2738	191	29.60
GEO2-1040-38	2336	12156	3563	9595	2812	196	30.40
GEO2-1040-39	2397	12476	3657	9847	2886	201	31.20
GEO2-1040-40	2458	12796	3750	10100	2960	206	32.00

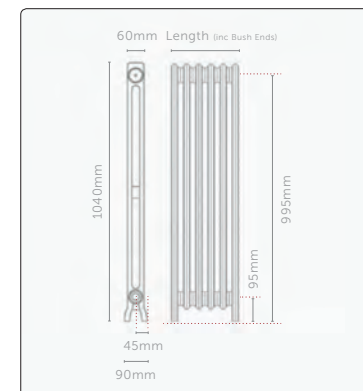
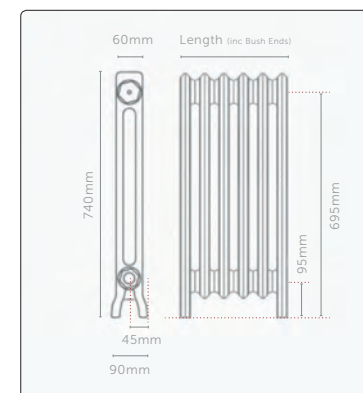

Dt50 figures shown in accordance with BS EN442. We have, from experience, found that the Dt60 figures usually give adequate output without oversizing the radiators on standard heating systems. Maximum test pressure = 3.3 bar | Maximum working pressure = 2.5 bar. Lengths quoted are given in good faith. However, due to the nature of the manufacturing process tolerances can and should be expected. Quoted dimensions should therefore only be used as a guideline. Longer lengths are available on request.

Technical Data – Neo Georgian 4 column

See Page 20

360 mm

CODE/ SECTIONS	LENGTH	OUTPUT				WEIGHT (KG)	WATER CONTENT (LTRs)
		Dt60		Dt50			
		BTUs	WATTS	BTUs	WATTS		
GEO4-360-03	208	613	180	484	142	10	1.05
GEO4-360-04	269	818	240	646	189	14	1.40
GEO4-360-05	330	1022	300	807	237	17	1.75
GEO4-360-06	391	1227	360	968	284	21	2.10
GEO4-360-07	452	1431	420	1130	331	24	2.45
GEO4-360-08	512	1636	479	1291	378	28	2.80
GEO4-360-09	573	1840	539	1452	426	31	3.15
GEO4-360-10	634	2045	599	1614	473	34	3.50
GEO4-360-11	695	2249	659	1775	520	38	3.85
GEO4-360-12	756	2454	719	1937	568	41	4.20
GEO4-360-13	816	2658	779	2098	615	45	4.55
GEO4-360-14	877	2863	839	2259	662	48	4.90
GEO4-360-15	938	3067	899	2421	710	52	5.25
GEO4-360-16	999	3272	959	2582	757	55	5.60
GEO4-360-17	1060	3476	1019	2744	804	59	5.95
GEO4-360-18	1120	3681	1079	2905	851	62	6.30
GEO4-360-19	1181	3885	1139	3066	899	65	6.65
GEO4-360-20	1242	4090	1199	3228	946	69	7.00
GEO4-360-21	1303	4294	1259	3389	993	72	7.35
GEO4-360-22	1364	4499	1318	3551	1041	76	7.70
GEO4-360-23	1424	4703	1378	3712	1088	79	8.05
GEO4-360-24	1485	4907	1438	3873	1135	83	8.40
GEO4-360-25	1546	5112	1498	4035	1183	86	8.75
GEO4-360-26	1607	5316	1558	4196	1230	89	9.10
GEO4-360-27	1668	5521	1618	4357	1277	93	9.45
GEO4-360-28	1728	5725	1678	4519	1324	96	9.80
GEO4-360-29	1789	5930	1738	4680	1372	100	10.15
GEO4-360-30	1850	6134	1798	4842	1419	103	10.50
GEO4-360-31	1911	6339	1858	5003	1466	107	10.85
GEO4-360-32	1972	6543	1918	5164	1514	110	11.20
GEO4-360-33	2032	6748	1978	5326	1561	114	11.55
GEO4-360-34	2093	6952	2038	5487	1608	117	11.90
GEO4-360-35	2154	7157	2098	5649	1656	120	12.25
GEO4-360-36	2215	7361	2157	5810	1703	124	12.60
GEO4-360-37	2276	7566	2217	5971	1750	127	12.95
GEO4-360-38	2336	7770	2277	6133	1797	131	13.30
GEO4-360-39	2397	7975	2337	6294	1845	134	13.65
GEO4-360-40	2458	8179	2397	6456	1892	138	14.00

505 mm

CODE/ SECTIONS	LENGTH	OUTPUT				WEIGHT (KG)	WATER CONTENT (LTRs)
		Dt60		Dt50			
		BTUs	WATTS	BTUs	WATTS		
GEO4-505-03	208	872	255	688	202	13	1.53
GEO4-505-04	269	1162	341	917	269	17	2.04
GEO4-505-05	330	1453	426	1146	336	21	2.55
GEO4-505-06	391	1743	511	1376	403	25	3.06
GEO4-505-07	452	2034	596	1605	470	29	3.57
GEO4-505-08	512	2324	681	1834	538	34	4.08
GEO4-505-09	573	2615	766	2064	605	38	4.59
GEO4-505-10	634	2905	851	2293	672	42	5.10
GEO4-505-11	695	3196	937	2522	739	46	5.61
GEO4-505-12	756	3486	1022	2751	806	50	6.12
GEO4-505-13	816	3777	1107	2981	874	55	6.63
GEO4-505-14	877	4067	1192	3210	941	59	7.14
GEO4-505-15	938	4358	1277	3439	1008	63	7.65
GEO4-505-16	999	4648	1362	3669	1075	67	8.16
GEO4-505-17	1060	4939	1447	3898	1142	71	8.67
GEO4-505-18	1120	5229	1533	4127	1210	75	9.18
GEO4-505-19	1181	5520	1618	4356	1277	80	9.69
GEO4-505-20	1242	5810	1703	4586	1344	84	10.20
GEO4-505-21	1303	6101	1788	4815	1411	88	10.71
GEO4-505-22	1364	6391	1873	5044	1478	92	11.22
GEO4-505-23	1424	6682	1958	5274	1546	96	11.73
GEO4-505-24	1485	6972	2043	5503	1613	101	12.24
GEO4-505-25	1546	7263	2129	5732	1680	105	12.75
GEO4-505-26	1607	7553	2214	5961	1747	109	13.26
GEO4-505-27	1668	7844	2299	6191	1814	113	13.77
GEO4-505-28	1728	8134	2384	6420	1882	117	14.28
GEO4-505-29	1789	8425	2469	6649	1949	122	14.79
GEO4-505-30	1850	8715	2554	6879	2016	126	15.30
GEO4-505-31	1911	9006	2639	7108	2083	130	15.81
GEO4-505-32	1972	9296	2725	7337	2150	134	16.32
GEO4-505-33	2032	9587	2810	7566	2218	138	16.83
GEO4-505-34	2093	9877	2895	7796	2285	143	17.34
GEO4-505-35	2154	10168	2980	8025	2352	147	17.85
GEO4-505-36	2215	10458	3065	8254	2419	151	18.36
GEO4-505-37	2276	10749	3150	8484	2486	155	18.87
GEO4-505-38	2336	11039	3235	8713	2554	159	19.38
GEO4-505-39	2397	11330	3321	8942	2621	163	19.89
GEO4-505-40	2458	11620	3406	9171	2688	168	20.40

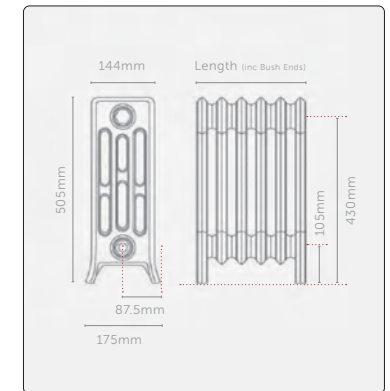
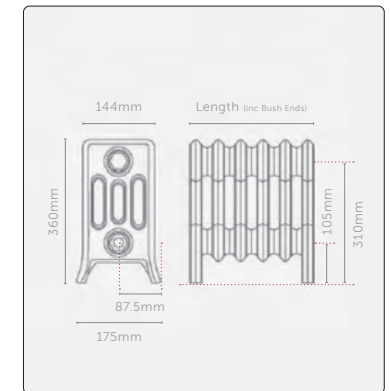

Dt50 figures shown in accordance with BS EN442. We have, from experience, found that the Dt60 figures usually give adequate output without oversizing the radiators on standard heating systems. Maximum test pressure = 3.3 bar | Maximum working pressure = 2.5 bar. Lengths quoted are given in good faith. However, due to the nature of the manufacturing process tolerances can and should be expected. Quoted dimensions should therefore only be used as a guideline. Longer lengths are available on request.

Technical Data – Neo Georgian 4 column

660 mm

CODE/ SECTIONS	LENGTH	OUTPUT				WEIGHT (KG)	WATER CONTENT (LTRs)
		Dt60		Dt50			
		BTUs	WATTS	BTUs	WATTS		
GEO4-660-03	208	1145	336	904	265	17	2.55
GEO4-660-04	269	1527	448	1205	353	22	3.40
GEO4-660-05	330	1909	559	1506	442	28	4.25
GEO4-660-06	391	2290	671	1808	530	33	5.10
GEO4-660-07	452	2672	783	2109	618	39	5.95
GEO4-660-08	512	3054	895	2410	706	44	6.80
GEO4-660-09	573	3435	1007	2712	795	50	7.65
GEO4-660-10	634	3817	1119	3013	883	56	8.50
GEO4-660-11	695	4199	1231	3314	971	61	9.35
GEO4-660-12	756	4581	1343	3615	1060	67	10.20
GEO4-660-13	816	4962	1454	3917	1148	72	11.05
GEO4-660-14	877	5344	1566	4218	1236	78	11.90
GEO4-660-15	938	5726	1678	4519	1325	83	12.75
GEO4-660-16	999	6108	1790	4820	1413	89	13.60
GEO4-660-17	1060	6489	1902	5122	1501	94	14.45
GEO4-660-18	1120	6871	2014	5423	1589	100	15.30
GEO4-660-19	1181	7253	2126	5724	1678	106	16.15
GEO4-660-20	1242	7634	2238	6026	1766	111	17.00
GEO4-660-21	1303	8016	2349	6327	1854	117	17.85
GEO4-660-22	1364	8398	2461	6628	1943	122	18.70
GEO4-660-23	1424	8780	2573	6929	2031	128	19.55
GEO4-660-24	1485	9161	2685	7231	2119	133	20.40
GEO4-660-25	1546	9543	2797	7532	2208	139	21.25
GEO4-660-26	1607	9925	2909	7833	2296	144	22.10
GEO4-660-27	1668	10306	3021	8135	2384	150	22.95
GEO4-660-28	1728	10688	3133	8436	2472	155	23.80
GEO4-660-29	1789	11070	3244	8737	2561	161	24.65
GEO4-660-30	1850	11452	3356	9038	2649	167	25.50
GEO4-660-31	1911	11833	3468	9340	2737	172	26.35
GEO4-660-32	1972	12215	3580	9641	2826	178	27.20
GEO4-660-33	2032	12597	3692	9942	2914	183	28.05
GEO4-660-34	2093	12979	3804	10244	3002	189	28.90
GEO4-660-35	2154	13360	3916	10545	3091	194	29.75
GEO4-660-36	2215	13742	4028	10846	3179	200	30.60
GEO4-660-37	2276	14124	4139	11147	3267	205	31.45
GEO4-660-38	2336	14505	4251	11449	3355	211	32.30
GEO4-660-39	2397	14887	4363	11750	3444	217	33.15
GEO4-660-40	2458	15269	4475	12051	3532	222	34.00

760 mm

CODE/ SECTIONS	LENGTH	OUTPUT				WEIGHT (KG)	WATER CONTENT (LTRs)
		Dt60		Dt50			
		BTUs	WATTS	BTUs	WATTS		
GEO4-760-03	208	1381	405	1090	320	19	3.00
GEO4-760-04	269	1842	540	1454	426	25	4.00
GEO4-760-05	330	2302	675	1817	533	31	5.00
GEO4-760-06	391	2762	810	2180	639	37	6.00
GEO4-760-07	452	3223	945	2544	746	44	7.00
GEO4-760-08	512	3683	1079	2907	852	50	8.00
GEO4-760-09	573	4144	1214	3270	959	56	9.00
GEO4-760-10	634	4604	1349	3634	1065	62	10.00
GEO4-760-11	695	5064	1484	3997	1172	68	11.00
GEO4-760-12	756	5525	1619	4361	1278	75	12.00
GEO4-760-13	816	5985	1754	4724	1385	81	13.00
GEO4-760-14	877	6446	1889	5087	1491	87	14.00
GEO4-760-15	938	6906	2024	5451	1598	93	15.00
GEO4-760-16	999	7366	2159	5814	1704	100	16.00
GEO4-760-17	1060	7827	2294	6177	1811	106	17.00
GEO4-760-18	1120	8287	2429	6541	1917	112	18.00
GEO4-760-19	1181	8748	2564	6904	2024	118	19.00
GEO4-760-20	1242	9208	2699	7268	2130	124	20.00
GEO4-760-21	1303	9668	2834	7631	2237	131	21.00
GEO4-760-22	1364	10129	2969	7994	2343	137	22.00
GEO4-760-23	1424	10589	3104	8358	2450	143	23.00
GEO4-760-24	1485	11050	3238	8721	2556	149	24.00
GEO4-760-25	1546	11510	3373	9084	2663	156	25.00
GEO4-760-26	1607	11970	3508	9448	2769	162	26.00
GEO4-760-27	1668	12431	3643	9811	2876	168	27.00
GEO4-760-28	1728	12891	3778	10175	2982	174	28.00
GEO4-760-29	1789	13352	3913	10538	3089	180	29.00
GEO4-760-30	1850	13812	4048	10901	3195	187	30.00
GEO4-760-31	1911	14272	4183	11265	3302	193	31.00
GEO4-760-32	1972	14733	4318	11628	3408	199	32.00
GEO4-760-33	2032	15193	4453	11991	3515	205	33.00
GEO4-760-34	2093	15654	4588	12355	3621	211	34.00
GEO4-760-35	2154	16114	4723	12718	3728	218	35.00
GEO4-760-36	2215	16574	4858	13082	3834	224	36.00
GEO4-760-37	2276	17035	4993	13445	3941	230	37.00
GEO4-760-38	2336	17495	5128	13808	4047	236	38.00
GEO4-760-39	2397	17956	5262	14172	4154	243	39.00
GEO4-760-40	2458	18416	5397	14535	4260	249	40.00

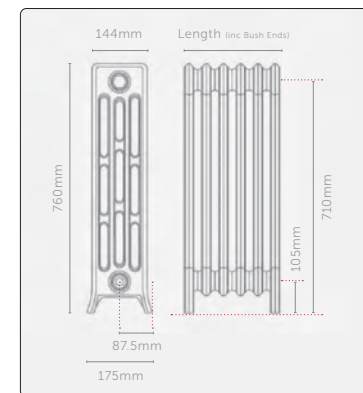
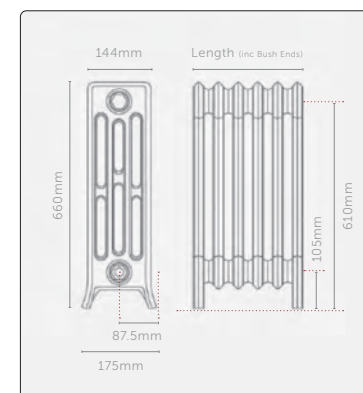

Dt50 figures shown in accordance with BS EN442. We have, from experience, found that the Dt60 figures usually give adequate output without oversizing the radiators on standard heating systems. Maximum test pressure = 3.3 bar | Maximum working pressure = 2.5 bar. Lengths quoted are given in good faith. However, due to the nature of the manufacturing process tolerances can and should be expected. Quoted dimensions should therefore only be used as a guideline. Longer lengths are available on request.

Technical Data – Neo Georgian 4 column

960 mm

CODE/ SECTIONS	LENGTH	OUTPUT				WEIGHT (KG)	WATER CONTENT (LTRs)
		Dt60		Dt50			
		BTUs	WATTS	BTUs	WATTS		
GEO4-960-03	208	1652	484	1304	382	24	3.30
GEO4-960-04	269	2203	646	1739	510	31	4.40
GEO4-960-05	330	2754	807	2173	637	39	5.50
GEO4-960-06	391	3305	968	2608	764	47	6.60
GEO4-960-07	452	3855	1130	3043	892	55	7.70
GEO4-960-08	512	4406	1291	3478	1019	63	8.80
GEO4-960-09	573	4957	1453	3912	1147	71	9.90
GEO4-960-10	634	5508	1614	4347	1274	79	11.00
GEO4-960-11	695	6058	1776	4782	1401	86	12.10
GEO4-960-12	756	6609	1937	5216	1529	94	13.20
GEO4-960-13	816	7160	2098	5651	1656	102	14.30
GEO4-960-14	877	7711	2260	6086	1784	110	15.40
GEO4-960-15	938	8261	2421	6520	1911	118	16.50
GEO4-960-16	999	8812	2583	6955	2038	126	17.60
GEO4-960-17	1060	9363	2744	7390	2166	133	18.70
GEO4-960-18	1120	9914	2905	7824	2293	141	19.80
GEO4-960-19	1181	10464	3067	8259	2421	149	20.90
GEO4-960-20	1242	11015	3228	8694	2548	157	22.00
GEO4-960-21	1303	11566	3390	9128	2675	165	23.10
GEO4-960-22	1364	12117	3551	9563	2803	173	24.20
GEO4-960-23	1424	12667	3713	9998	2930	181	25.30
GEO4-960-24	1485	13218	3874	10433	3058	188	26.40
GEO4-960-25	1546	13769	4035	10867	3185	196	27.50
GEO4-960-26	1607	14320	4197	11302	3312	204	28.60
GEO4-960-27	1668	14870	4358	11737	3440	212	29.70
GEO4-960-28	1728	15421	4520	12171	3567	220	30.80
GEO4-960-29	1789	15972	4681	12606	3695	228	31.90
GEO4-960-30	1850	16523	4842	13041	3822	236	33.00
GEO4-960-31	1911	17073	5004	13475	3949	243	34.10
GEO4-960-32	1972	17624	5165	13910	4077	251	35.20
GEO4-960-33	2032	18175	5327	14345	4204	259	36.30
GEO4-960-34	2093	18726	5488	14779	4332	267	37.40
GEO4-960-35	2154	19276	5650	15214	4459	275	38.50
GEO4-960-36	2215	19827	5811	15649	4586	283	39.60
GEO4-960-37	2276	20378	5972	16083	4714	290	40.70
GEO4-960-38	2336	20929	6134	16518	4841	298	41.80
GEO4-960-39	2397	21479	6295	16953	4969	306	42.90
GEO4-960-40	2458	22030	6457	17388	5096	314	44.00

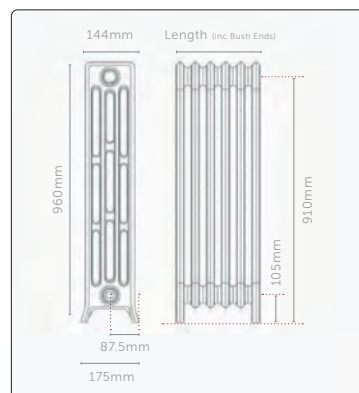

Dt50 figures shown in accordance with BS EN442. We have, from experience, found that the Dt60 figures usually give adequate output without oversizing the radiators on standard heating systems. Maximum test pressure = 3.3 bar | Maximum working pressure = 2.5 bar. Lengths quoted are given in good faith. However, due to the nature of the manufacturing process tolerances can and should be expected. Quoted dimensions should therefore only be used as a guideline. Longer lengths are available on request.

Technical Data – Neo Georgian 6 column

See Page 21

505 mm

CODE/ SECTIONS	LENGTH	OUTPUT				WEIGHT (KG)	WATER CONTENT (LTRs)
		Dt60		Dt50			
		BTUs	WATTS	BTUs	WATTS		
GEO6-505-03	208	1252	367	988	290	25	3.60
GEO6-505-04	269	1669	489	1317	386	33	4.80
GEO6-505-05	330	2086	611	1646	483	42	6.00
GEO6-505-06	391	2503	734	1976	579	50	7.20
GEO6-505-07	452	2920	856	2305	676	58	8.40
GEO6-505-08	512	3337	978	2634	772	67	9.60
GEO6-505-09	573	3755	1100	2963	869	75	10.80
GEO6-505-10	634	4172	1223	3293	965	84	12.00
GEO6-505-11	695	4589	1345	3622	1062	92	13.20
GEO6-505-12	756	5006	1467	3951	1158	100	14.40
GEO6-505-13	816	5423	1589	4280	1255	109	15.60
GEO6-505-14	877	5840	1712	4610	1351	117	16.80
GEO6-505-15	938	6258	1834	4939	1448	125	18.00
GEO6-505-16	999	6675	1956	5268	1544	134	19.20
GEO6-505-17	1060	7092	2079	5597	1641	142	20.40
GEO6-505-18	1120	7509	2201	5927	1737	150	21.60
GEO6-505-19	1181	7926	2323	6256	1834	159	22.80
GEO6-505-20	1242	8343	2445	6585	1930	167	24.00
GEO6-505-21	1303	8761	2568	6914	2027	175	25.20
GEO6-505-22	1364	9178	2690	7244	2123	184	26.40
GEO6-505-23	1424	9595	2812	7573	2220	192	27.60
GEO6-505-24	1485	10012	2934	7902	2316	200	28.80
GEO6-505-25	1546	10429	3057	8231	2413	209	30.00
GEO6-505-26	1607	10846	3179	8561	2509	217	31.20
GEO6-505-27	1668	11264	3301	8890	2606	225	32.40
GEO6-505-28	1728	11681	3423	9219	2702	234	33.60
GEO6-505-29	1789	12098	3546	9548	2799	242	34.80
GEO6-505-30	1850	12515	3668	9878	2895	251	36.00
GEO6-505-31	1911	12932	3790	10207	2992	259	37.20
GEO6-505-32	1972	13349	3912	10536	3088	267	38.40
GEO6-505-33	2032	13767	4035	10866	3185	276	39.60
GEO6-505-34	2093	14184	4157	11195	3281	284	40.80
GEO6-505-35	2154	14601	4279	11524	3378	292	42.00
GEO6-505-36	2215	15018	4402	11853	3474	301	43.20
GEO6-505-37	2276	15435	4524	12183	3571	309	44.40
GEO6-505-38	2336	15852	4646	12512	3667	317	45.60
GEO6-505-39	2397	16270	4768	12841	3764	326	46.80
GEO6-505-40	2458	16687	4891	13170	3860	334	48.00

660 mm

CODE/ SECTIONS	LENGTH	OUTPUT				WEIGHT (KG)	WATER CONTENT (LTRs)
		Dt60		Dt50			
		BTUs	WATTS	BTUs	WATTS		
GEO6-660-03	208	1641	481	1295	380	29	4.20
GEO6-660-04	269	2187	641	1726	506	38	5.60
GEO6-660-05	330	2734	801	2158	633	48	7.00
GEO6-660-06	391	3281	962	2590	759	58	8.40
GEO6-660-07	452	3828	1122	3021	886	67	9.80
GEO6-660-08	512	4375	1282	3453	1012	77	11.20
GEO6-660-09	573	4922	1442	3885	1139	86	12.60
GEO6-660-10	634	5469	1603	4316	1265	96	14.00
GEO6-660-11	695	6015	1763	4748	1392	105	15.40
GEO6-660-12	756	6562	1923	5179	1518	115	16.80
GEO6-660-13	816	7109	2084	5611	1645	125	18.20
GEO6-660-14	877	7656	2244	6043	1771	134	19.60
GEO6-660-15	938	8203	2404	6474	1898	144	21.00
GEO6-660-16	999	8750	2564	6906	2024	153	22.40
GEO6-660-17	1060	9297	2725	7338	2151	163	23.80
GEO6-660-18	1120	9843	2885	7769	2277	173	25.20
GEO6-660-19	1181	10390	3045	8201	2404	182	26.60
GEO6-660-20	1242	10937	3206	8632	2530	192	28.00
GEO6-660-21	1303	11484	3366	9064	2657	201	29.40
GEO6-660-22	1364	12031	3526	9496	2783	211	30.80
GEO6-660-23	1424	12578	3686	9927	2910	221	32.20
GEO6-660-24	1485	13125	3847	10359	3036	230	33.60
GEO6-660-25	1546	13672	4007	10790	3163	240	35.00
GEO6-660-26	1607	14218	4167	11222	3289	249	36.40
GEO6-660-27	1668	14765	4327	11654	3416	259	37.80
GEO6-660-28	1728	15312	4488	12085	3542	269	39.20
GEO6-660-29	1789	15859	4648	12517	3669	278	40.60
GEO6-660-30	1850	16406	4808	12949	3795	288	42.00
GEO6-660-31	1911	16953	4969	13380	3922	297	43.40
GEO6-660-32	1972	17500	5129	13812	4048	307	44.80
GEO6-660-33	2032	18046	5289	14243	4175	316	46.20
GEO6-660-34	2093	18593	5449	14675	4301	326	47.60
GEO6-660-35	2154	19140	5610	15107	4428	336	49.00
GEO6-660-36	2215	19687	5770	15538	4554	345	50.40
GEO6-660-37	2276	20234	5930	15970	4681	355	51.80
GEO6-660-38	2336	20781	6090	16401	4807	364	53.20
GEO6-660-39	2397	21328	6251	16833	4934	374	54.60
GEO6-660-40	2458	21874	6411	17265	5060	384	56.00

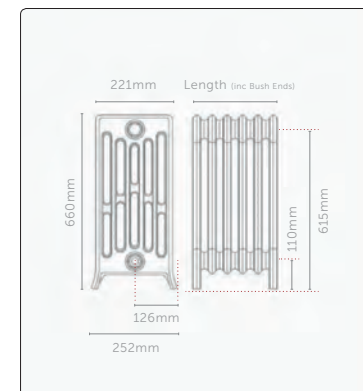
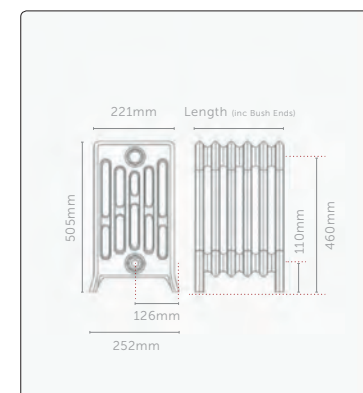

Dt50 figures shown in accordance with BS EN442. We have, from experience, found that the Dt60 figures usually give adequate output without oversizing the radiators on standard heating systems. Maximum test pressure = 3.3 bar | Maximum working pressure = 2.5 bar. Lengths quoted are given in good faith. However, due to the nature of the manufacturing process tolerances can and should be expected. Quoted dimensions should therefore only be used as a guideline. Longer lengths are available on request.

Technical Data – Neo Georgian 6 column

960 mm

CODE/ SECTIONS	LENGTH	OUTPUT				WEIGHT (KG)	WATER CONTENT (LTRs)
		Dt60		Dt50			
		BTUs	WATTS	BTUs	WATTS		
GEO6-960-03	208	2366	693	1867	547	37	4.80
GEO6-960-04	269	3154	924	2489	730	49	6.40
GEO6-960-05	330	3943	1156	3112	912	61	8.00
GEO6-960-06	391	4731	1387	3734	1094	74	9.60
GEO6-960-07	452	5520	1618	4356	1277	86	11.20
GEO6-960-08	512	6308	1849	4979	1459	98	12.80
GEO6-960-09	573	7097	2080	5601	1642	111	14.40
GEO6-960-10	634	7885	2311	6223	1824	123	16.00
GEO6-960-11	695	8674	2542	6846	2006	135	17.60
GEO6-960-12	756	9462	2773	7468	2189	147	19.20
GEO6-960-13	816	10251	3004	8091	2371	160	20.80
GEO6-960-14	877	11039	3235	8713	2554	172	22.40
GEO6-960-15	938	11828	3467	9335	2736	184	24.00
GEO6-960-16	999	12616	3698	9958	2918	196	25.60
GEO6-960-17	1060	13405	3929	10580	3101	209	27.20
GEO6-960-18	1120	14193	4160	11202	3283	221	28.80
GEO6-960-19	1181	14982	4391	11825	3466	233	30.40
GEO6-960-20	1242	15770	4622	12447	3648	246	32.00
GEO6-960-21	1303	16559	4853	13069	3830	258	33.60
GEO6-960-22	1364	17347	5084	13692	4013	270	35.20
GEO6-960-23	1424	18136	5315	14314	4195	282	36.80
GEO6-960-24	1485	18924	5546	14936	4378	295	38.40
GEO6-960-25	1546	19713	5778	15559	4560	307	40.00
GEO6-960-26	1607	20501	6009	16181	4742	319	41.60
GEO6-960-27	1668	21290	6240	16803	4925	332	43.20
GEO6-960-28	1728	22078	6471	17426	5107	344	44.80
GEO6-960-29	1789	22867	6702	18048	5290	356	46.40
GEO6-960-30	1850	23655	6933	18670	5472	368	48.00
GEO6-960-31	1911	24444	7164	19293	5654	381	49.60
GEO6-960-32	1972	25233	7395	19915	5837	393	51.20
GEO6-960-33	2032	26021	7626	20538	6019	405	52.80
GEO6-960-34	2093	26810	7857	21160	6202	418	54.40
GEO6-960-35	2154	27598	8089	21782	6384	430	56.00
GEO6-960-36	2215	28387	8320	22405	6566	442	57.60
GEO6-960-37	2276	29175	8551	23027	6749	454	59.20
GEO6-960-38	2336	29964	8782	23649	6931	467	60.80
GEO6-960-39	2397	30752	9013	24272	7114	479	62.40
GEO6-960-40	2458	31541	9244	24894	7296	491	64.00

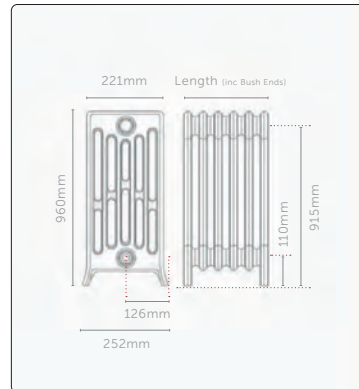

Dt50 figures shown in accordance with BS EN442. We have, from experience, found that the Dt60 figures usually give adequate output without oversizing the radiators on standard heating systems. Maximum test pressure = 3.3 bar | Maximum working pressure = 2.5 bar. Lengths quoted are given in good faith. However, due to the nature of the manufacturing process tolerances can and should be expected. Quoted dimensions should therefore only be used as a guideline. Longer lengths are available on request.

470 mm

CODE/ SECTIONS	LENGTH	OUTPUT				WEIGHT (KG)	WATER CONTENT (LTRs)
		Dt60		Dt50			
		BTUs	WATTS	BTUs	WATTS		
OXF-470-03	278	1237	363	977	286	25	5.10
OXF-470-04	359	1650	483	1302	382	33	6.80
OXF-470-05	440	2062	604	1628	477	41	8.50
OXF-470-06	521	2474	725	1953	572	49	10.20
OXF-470-07	602	2887	846	2279	668	58	11.90
OXF-470-08	684	3299	967	2604	763	66	13.60
OXF-470-09	765	3712	1088	2930	859	74	15.30
OXF-470-10	846	4124	1209	3255	954	82	17.00
OXF-470-11	927	4537	1330	3581	1049	91	18.70
OXF-470-12	1008	4949	1450	3906	1145	99	20.40
OXF-470-13	1090	5361	1571	4232	1240	107	22.10
OXF-470-14	1171	5774	1692	4557	1336	115	23.80
OXF-470-15	1252	6186	1813	4883	1431	124	25.50
OXF-470-16	1333	6599	1934	5208	1526	132	27.20
OXF-470-17	1414	7011	2055	5534	1622	140	28.90
OXF-470-18	1496	7423	2176	5859	1717	148	30.60
OXF-470-19	1577	7836	2297	6185	1813	157	32.30
OXF-470-20	1658	8248	2417	6510	1908	165	34.00
OXF-470-21	1739	8661	2538	6836	2003	173	35.70
OXF-470-22	1820	9073	2659	7161	2099	181	37.40
OXF-470-23	1902	9486	2780	7487	2194	189	39.10
OXF-470-24	1983	9898	2901	7812	2290	198	40.80
OXF-470-25	2064	10310	3022	8138	2385	206	42.50
OXF-470-26	2145	10723	3143	8463	2480	214	44.20
OXF-470-27	2226	11135	3264	8789	2576	223	45.90
OXF-470-28	2308	11548	3384	9114	2671	231	47.60
OXF-470-29	2389	11960	3505	9440	2767	239	49.30
OXF-470-30	2470	12372	3626	9765	2862	247	51.00
OXF-470-31	2551	12785	3747	10091	2957	255	52.70
OXF-470-32	2632	13197	3868	10416	3053	264	54.40
OXF-470-33	2714	13610	3989	10742	3148	272	56.10
OXF-470-34	2795	14022	4110	11067	3244	280	57.80
OXF-470-35	2876	14435	4231	11393	3339	288	59.50
OXF-470-36	2957	14847	4351	11718	3434	297	61.20
OXF-470-37	3038	15259	4472	12044	3530	305	62.90
OXF-470-38	3120	15672	4593	12369	3625	313	64.60
OXF-470-39	3201	16084	4714	12695	3721	321	66.30
OXF-470-40	3282	16497	4835	13020	3816	330	68.00

570 mm

CODE/ SECTIONS	LENGTH	OUTPUT				WEIGHT (KG)	WATER CONTENT (LTRs)
		Dt60		Dt50			
		BTUs	WATTS	BTUs	WATTS		
OXF-570-03	276	1491	437	1177	345	30	6.30
OXF-570-04	357	1989	583	1570	460	40	8.40
OXF-570-05	438	2486	729	1962	575	50	10.50
OXF-570-06	518	2983	874	2354	690	60	12.60
OXF-570-07	599	3480	1020	2747	805	69	14.70
OXF-570-08	680	3977	1166	3139	920	79	16.80
OXF-570-09	760	4474	1311	3531	1035	89	18.90
OXF-570-10	841	4971	1457	3924	1150	99	21.00
OXF-570-11	922	5469	1603	4316	1265	109	23.10
OXF-570-12	1002	5966	1748	4709	1380	119	25.20
OXF-570-13	1083	6463	1894	5101	1495	129	27.30
OXF-570-14	1164	6960	2040	5493	1610	139	29.40
OXF-570-15	1245	7457	2186	5886	1725	149	31.50
OXF-570-16	1325	7954	2331	6278	1840	159	33.60
OXF-570-17	1406	8451	2477	6670	1955	169	35.70
OXF-570-18	1487	8949	2623	7063	2070	179	37.80
OXF-570-19	1567	9446	2768	7455	2185	189	39.90
OXF-570-20	1648	9943	2914	7848	2300	198	42.00
OXF-570-21	1729	10440	3060	8240	2415	208	44.10
OXF-570-22	1809	10937	3206	8632	2530	218	46.20
OXF-570-23	1890	11434	3351	9025	2645	228	48.30
OXF-570-24	1971	11931	3497	9417	2760	238	50.40
OXF-570-25	2052	12429	3643	9810	2875	248	52.50
OXF-570-26	2132	12926	3788	10202	2990	258	54.60
OXF-570-27	2213	13423	3934	10594	3105	268	56.70
OXF-570-28	2294	13920	4080	10987	3220	278	58.80
OXF-570-29	2374	14417	4225	11379	3335	288	60.90
OXF-570-30	2455	14914	4371	11771	3450	298	63.00
OXF-570-31	2536	15412	4517	12164	3565	308	65.10
OXF-570-32	2616	15909	4663	12556	3680	317	67.20
OXF-570-33	2697	16406	4808	12949	3795	327	69.30
OXF-570-34	2778	16903	4954	13341	3910	337	71.40
OXF-570-35	2859	17400	5100	13733	4025	347	73.50
OXF-570-36	2939	17897	5245	14126	4140	357	75.60
OXF-570-37	3020	18394	5391	14518	4255	367	77.70
OXF-570-38	3101	18892	5537	14910	4370	377	79.80
OXF-570-39	3181	19389	5682	15303	4485	387	81.90
OXF-570-40	3262	19886	5828	15695	4600	397	84.00

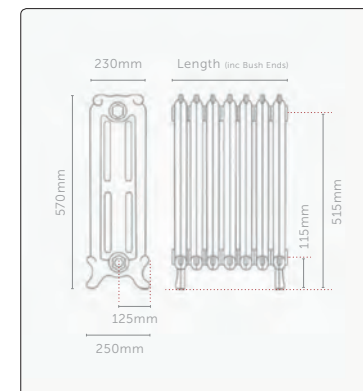
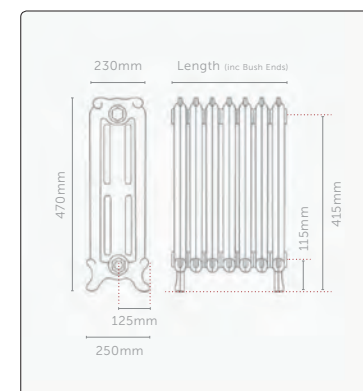

Dt50 figures shown in accordance with BS EN442. We have, from experience, found that the Dt60 figures usually give adequate output without oversizing the radiators on standard heating systems. Maximum test pressure = 3.3 bar | Maximum working pressure = 2.5 bar. Lengths quoted are given in good faith. However, due to the nature of the manufacturing process tolerances can and should be expected. Quoted dimensions should therefore only be used as a guideline. Longer lengths are available on request.

Technical Data – Oxford

765 mm

CODE/ SECTIONS	LENGTH	OUTPUT				WEIGHT (KG)	WATER CONTENT (LTRs)
		Dt60		Dt50			
		BTUs	WATTS	BTUs	WATTS		
OXF-765-03	278	2019	592	1594	467	44	8.10
OXF-765-04	359	2692	789	2125	623	59	10.80
OXF-765-05	440	3365	986	2656	779	74	13.50
OXF-765-06	521	4039	1184	3187	934	89	16.20
OXF-765-07	602	4712	1381	3719	1090	103	18.90
OXF-765-08	684	5385	1578	4250	1246	118	21.60
OXF-765-09	765	6058	1775	4781	1401	133	24.30
OXF-765-10	846	6731	1973	5312	1557	148	27.00
OXF-765-11	927	7404	2170	5844	1713	162	29.70
OXF-765-12	1008	8077	2367	6375	1868	177	32.40
OXF-765-13	1090	8750	2565	6906	2024	192	35.10
OXF-765-14	1171	9423	2762	7437	2180	207	37.80
OXF-765-15	1252	10096	2959	7969	2336	221	40.50
OXF-765-16	1333	10769	3156	8500	2491	236	43.20
OXF-765-17	1414	11443	3354	9031	2647	251	45.90
OXF-765-18	1496	12116	3551	9562	2803	266	48.60
OXF-765-19	1577	12789	3748	10094	2958	280	51.30
OXF-765-20	1658	13462	3945	10625	3114	295	54.00
OXF-765-21	1739	14135	4143	11156	3270	310	56.70
OXF-765-22	1820	14808	4340	11687	3425	325	59.40
OXF-765-23	1902	15481	4537	12219	3581	340	62.10
OXF-765-24	1983	16154	4735	12750	3737	354	64.80
OXF-765-25	2064	16827	4932	13281	3893	369	67.50
OXF-765-26	2145	17500	5129	13812	4048	384	70.20
OXF-765-27	2226	18173	5326	14344	4204	399	72.90
OXF-765-28	2308	18847	5524	14875	4360	413	75.60
OXF-765-29	2389	19520	5721	15406	4515	428	78.30
OXF-765-30	2470	20193	5918	15937	4671	443	81.00
OXF-765-31	2551	20866	6115	16469	4827	458	83.70
OXF-765-32	2632	21539	6313	17000	4982	472	86.40
OXF-765-33	2714	22212	6510	17531	5138	487	89.10
OXF-765-34	2795	22885	6707	18062	5294	502	91.80
OXF-765-35	2876	23558	6905	18594	5450	517	94.50
OXF-765-36	2957	24231	7102	19125	5605	531	97.20
OXF-765-37	3038	24904	7299	19656	5761	546	99.90
OXF-765-38	3120	25577	7496	20187	5917	561	102.60
OXF-765-39	3201	26251	7694	20719	6072	576	105.30
OXF-765-40	3282	26924	7891	21250	6228	590	108.00

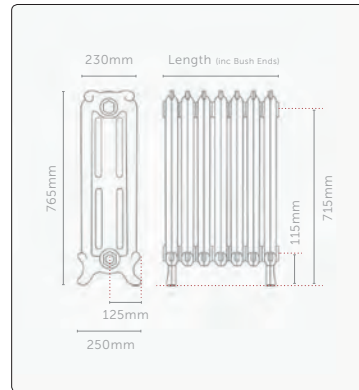

Dt50 figures shown in accordance with BS EN442. We have, from experience, found that the Dt60 figures usually give adequate output without oversizing the radiators on standard heating systems. Maximum test pressure = 3.3 bar | Maximum working pressure = 2.5 bar. Lengths quoted are given in good faith. However, due to the nature of the manufacturing process tolerances can and should be expected. Quoted dimensions should therefore only be used as a guideline. Longer lengths are available on request.

460 mm

CODE/ SECTIONS	LENGTH	OUTPUT				WEIGHT (KG)	WATER CONTENT (LTRs)
		Dt60		Dt50			
		BTUs	WATTS	BTUs	WATTS		
PIC-460-03	249	917	269	724	212	19	4.13
PIC-460-04	320	1223	358	965	283	25	5.50
PIC-460-05	392	1529	448	1207	354	32	6.88
PIC-460-06	463	1835	538	1448	424	38	8.25
PIC-460-07	535	2140	627	1689	495	44	9.63
PIC-460-08	606	2446	717	1931	566	51	11.00
PIC-460-09	678	2752	807	2172	637	57	12.38
PIC-460-10	749	3058	896	2413	707	63	13.75
PIC-460-11	821	3363	986	2655	778	70	15.13
PIC-460-12	892	3669	1075	2896	849	76	16.50
PIC-460-13	964	3975	1165	3137	919	82	17.88
PIC-460-14	1035	4281	1255	3379	990	89	19.25
PIC-460-15	1107	4586	1344	3620	1061	95	20.63
PIC-460-16	1178	4892	1434	3861	1132	101	22.00
PIC-460-17	1250	5198	1523	4103	1202	108	23.38
PIC-460-18	1321	5504	1613	4344	1273	114	24.75
PIC-460-19	1393	5810	1703	4585	1344	121	26.13
PIC-460-20	1464	6115	1792	4827	1415	127	27.50
PIC-460-21	1536	6421	1882	5068	1485	133	28.88
PIC-460-22	1607	6727	1972	5309	1556	140	30.25
PIC-460-23	1679	7033	2061	5551	1627	146	31.63
PIC-460-24	1750	7338	2151	5792	1698	152	33.00
PIC-460-25	1822	7644	2240	6033	1768	159	34.38
PIC-460-26	1893	7950	2330	6275	1839	165	35.75
PIC-460-27	1965	8256	2420	6516	1910	171	37.13
PIC-460-28	2036	8561	2509	6757	1980	178	38.50
PIC-460-29	2108	8867	2599	6999	2051	184	39.88
PIC-460-30	2179	9173	2688	7240	2122	190	41.25
PIC-460-31	2251	9479	2778	7481	2193	197	42.63
PIC-460-32	2322	9785	2868	7723	2263	203	44.00
PIC-460-33	2394	10090	2957	7964	2334	209	45.38
PIC-460-34	2465	10396	3047	8205	2405	216	46.75
PIC-460-35	2537	10702	3137	8447	2476	222	48.13
PIC-460-36	2608	11008	3226	8688	2546	228	49.50
PIC-460-37	2680	11313	3316	8929	2617	235	50.88
PIC-460-38	2751	11619	3405	9171	2688	241	52.25
PIC-460-39	2823	11925	3495	9412	2758	247	53.63
PIC-460-40	2894	12231	3585	9653	2829	254	55.00

660 mm

CODE/ SECTIONS	LENGTH	OUTPUT				WEIGHT (KG)	WATER CONTENT (LTRs)
		Dt60		Dt50			
		BTUs	WATTS	BTUs	WATTS		
PIC-660-03	247	1332	390	1052	308	28	7.05
PIC-660-04	318	1776	521	1402	411	38	9.40
PIC-660-05	389	2221	651	1753	514	47	11.75
PIC-660-06	460	2665	781	2103	616	57	14.10
PIC-660-07	531	3109	911	2454	719	66	16.45
PIC-660-08	602	3553	1041	2804	822	75	18.80
PIC-660-09	673	3997	1171	3155	925	85	21.15
PIC-660-10	744	4441	1302	3505	1027	94	23.50
PIC-660-11	815	4885	1432	3856	1130	104	25.85
PIC-660-12	886	5329	1562	4206	1233	113	28.20
PIC-660-13	957	5773	1692	4557	1335	123	30.55
PIC-660-14	1028	6217	1822	4907	1438	132	32.90
PIC-660-15	1099	6662	1952	5258	1541	141	35.25
PIC-660-16	1170	7106	2083	5608	1644	151	37.60
PIC-660-17	1241	7550	2213	5959	1746	160	39.95
PIC-660-18	1312	7994	2343	6309	1849	170	42.30
PIC-660-19	1383	8438	2473	6660	1952	179	44.65
PIC-660-20	1454	8882	2603	7010	2055	188	47.00
PIC-660-21	1525	9326	2733	7361	2157	198	49.35
PIC-660-22	1596	9770	2863	7711	2260	207	51.70
PIC-660-23	1667	10214	2994	8062	2363	217	54.05
PIC-660-24	1738	10658	3124	8412	2466	226	56.40
PIC-660-25	1809	11103	3254	8763	2568	236	58.75
PIC-660-26	1880	11547	3384	9113	2671	245	61.10
PIC-660-27	1951	11991	3514	9464	2774	254	63.45
PIC-660-28	2022	12435	3644	9814	2876	264	65.80
PIC-660-29	2093	12879	3775	10165	2979	273	68.15
PIC-660-30	2164	13323	3905	10515	3082	283	70.50
PIC-660-31	2235	13767	4035	10866	3185	292	72.85
PIC-660-32	2306	14211	4165	11216	3287	301	75.20
PIC-660-33	2377	14655	4295	11567	3390	311	77.55
PIC-660-34	2448	15099	4425	11918	3493	320	79.90
PIC-660-35	2519	15544	4555	12268	3596	330	82.25
PIC-660-36	2590	15988	4686	12619	3698	339	84.60
PIC-660-37	2661	16432	4816	12969	3801	349	86.95
PIC-660-38	2732	16876	4946	13320	3904	358	89.30
PIC-660-39	2803	17320	5076	13670	4006	367	91.65
PIC-660-40	2874	17764	5206	14021	4109	377	94.00

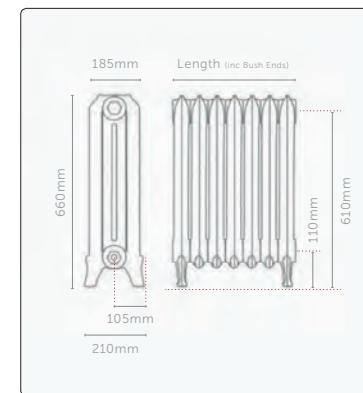
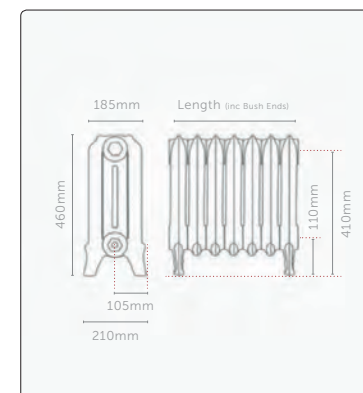

Dt50 figures shown in accordance with BS EN442. We have, from experience, found that the Dt60 figures usually give adequate output without oversizing the radiators on standard heating systems. Maximum test pressure = 3.3 bar | Maximum working pressure = 2.5 bar. Lengths quoted are given in good faith. However, due to the nature of the manufacturing process tolerances can and should be expected. Quoted dimensions should therefore only be used as a guideline. Longer lengths are available on request.

Technical Data – Piccadilly

760 mm

CODE/ SECTIONS	LENGTH	OUTPUT				WEIGHT (KG)	WATER CONTENT (LTRs)
		Dt60		Dt50			
		BTUs	WATTS	BTUs	WATTS		
PIC-760-03	247	1496	438	1181	346	31	7.20
PIC-760-04	318	1995	585	1574	461	41	9.60
PIC-760-05	389	2494	731	1968	577	52	12.00
PIC-760-06	460	2992	877	2362	692	62	14.40
PIC-760-07	531	3491	1023	2755	808	72	16.80
PIC-760-08	602	3990	1169	3149	923	83	19.20
PIC-760-09	673	4488	1315	3542	1038	93	21.60
PIC-760-10	744	4987	1462	3936	1154	103	24.00
PIC-760-11	815	5486	1608	4330	1269	114	26.40
PIC-760-12	886	5984	1754	4723	1384	124	28.80
PIC-760-13	957	6483	1900	5117	1500	134	31.20
PIC-760-14	1028	6982	2046	5511	1615	145	33.60
PIC-760-15	1099	7481	2192	5904	1730	155	36.00
PIC-760-16	1170	7979	2339	6298	1846	165	38.40
PIC-760-17	1241	8478	2485	6691	1961	175	40.80
PIC-760-18	1312	8977	2631	7085	2076	186	43.20
PIC-760-19	1383	9475	2777	7479	2192	196	45.60
PIC-760-20	1454	9974	2923	7872	2307	206	48.00
PIC-760-21	1525	10473	3069	8266	2423	217	50.40
PIC-760-22	1596	10971	3216	8659	2538	227	52.80
PIC-760-23	1667	11470	3362	9053	2653	237	55.20
PIC-760-24	1738	11969	3508	9447	2769	248	57.60
PIC-760-25	1809	12468	3654	9840	2884	258	60.00
PIC-760-26	1880	12966	3800	10234	2999	268	62.40
PIC-760-27	1951	13465	3946	10627	3115	279	64.80
PIC-760-28	2022	13964	4093	11021	3230	289	67.20
PIC-760-29	2093	14462	4239	11415	3345	299	69.60
PIC-760-30	2164	14961	4385	11808	3461	310	72.00
PIC-760-31	2235	15460	4531	12202	3576	320	74.40
PIC-760-32	2306	15958	4677	12595	3692	330	76.80
PIC-760-33	2377	16457	4823	12989	3807	341	79.20
PIC-760-34	2448	16956	4969	13383	3922	351	81.60
PIC-760-35	2519	17455	5116	13776	4038	361	84.00
PIC-760-36	2590	17953	5262	14170	4153	372	86.40
PIC-760-37	2661	18452	5408	14564	4268	382	88.80
PIC-760-38	2732	18951	5554	14957	4384	392	91.20
PIC-760-39	2803	19449	5700	15351	4499	403	93.60
PIC-760-40	2874	19948	5846	15744	4614	413	96.00

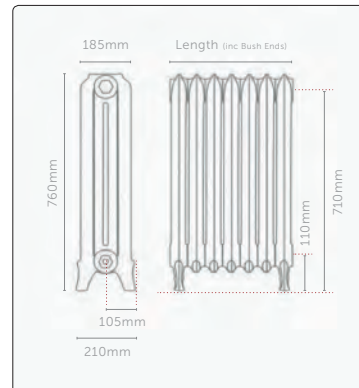

Dt50 figures shown in accordance with BS EN442. We have, from experience, found that the Dt60 figures usually give adequate output without oversizing the radiators on standard heating systems. Maximum test pressure = 3.3 bar | Maximum working pressure = 2.5 bar. Lengths quoted are given in good faith. However, due to the nature of the manufacturing process tolerances can and should be expected. Quoted dimensions should therefore only be used as a guideline. Longer lengths are available on request.

460 mm

CODE/ SECTIONS	LENGTH	OUTPUT				WEIGHT (KG)	WATER CONTENT (LTRs)
		Dt60		Dt50			
		BTUs	WATTS	BTUs	WATTS		
PIM-460-03	216	574	168	453	133	9	2.10
PIM-460-04	276	765	224	604	177	12	2.80
PIM-460-05	337	956	280	755	221	15	3.50
PIM-460-06	398	1147	336	905	265	18	4.20
PIM-460-07	458	1338	392	1056	310	21	4.90
PIM-460-08	519	1530	448	1207	354	25	5.60
PIM-460-09	579	1721	504	1358	398	28	6.30
PIM-460-10	640	1912	560	1509	442	31	7.00
PIM-460-11	701	2103	616	1660	487	34	7.70
PIM-460-12	761	2294	672	1811	531	37	8.40
PIM-460-13	822	2486	729	1962	575	40	9.10
PIM-460-14	882	2677	785	2113	619	43	9.80
PIM-460-15	943	2868	841	2264	663	46	10.50
PIM-460-16	1004	3059	897	2415	708	49	11.20
PIM-460-17	1064	3251	953	2566	752	52	11.90
PIM-460-18	1125	3442	1009	2716	796	55	12.60
PIM-460-19	1185	3633	1065	2867	840	58	13.30
PIM-460-20	1246	3824	1121	3018	885	61	14.00
PIM-460-21	1307	4015	1177	3169	929	64	14.70
PIM-460-22	1367	4207	1233	3320	973	67	15.40
PIM-460-23	1428	4398	1289	3471	1017	70	16.10
PIM-460-24	1488	4589	1345	3622	1062	73	16.80
PIM-460-25	1549	4780	1401	3773	1106	77	17.50
PIM-460-26	1610	4971	1457	3924	1150	80	18.20
PIM-460-27	1670	5163	1513	4075	1194	83	18.90
PIM-460-28	1731	5354	1569	4226	1238	86	19.60
PIM-460-29	1791	5545	1625	4376	1283	89	20.30
PIM-460-30	1852	5736	1681	4527	1327	92	21.00
PIM-460-31	1913	5927	1737	4678	1371	95	21.70
PIM-460-32	1973	6119	1793	4829	1415	98	22.40
PIM-460-33	2034	6310	1849	4980	1460	101	23.10
PIM-460-34	2094	6501	1905	5131	1504	104	23.80
PIM-460-35	2155	6692	1961	5282	1548	107	24.50
PIM-460-36	2216	6883	2017	5433	1592	110	25.20
PIM-460-37	2276	7075	2073	5584	1637	113	25.90
PIM-460-38	2337	7266	2129	5735	1681	116	26.60
PIM-460-39	2397	7457	2186	5886	1725	119	27.30
PIM-460-40	2458	7648	2242	6037	1769	122	28.00

660 mm

CODE/ SECTIONS	LENGTH	OUTPUT				WEIGHT (KG)	WATER CONTENT (LTRs)
		Dt60		Dt50			
		BTUs	WATTS	BTUs	WATTS		
PIM-660-03	218	839	246	662	194	13	3.00
PIM-660-04	279	1119	328	883	259	17	4.00
PIM-660-05	341	1398	410	1104	323	22	5.00
PIM-660-06	402	1678	492	1324	388	26	6.00
PIM-660-07	463	1958	574	1545	453	30	7.00
PIM-660-08	524	2237	656	1766	518	35	8.00
PIM-660-09	586	2517	738	1987	582	39	9.00
PIM-660-10	647	2797	820	2207	647	43	10.00
PIM-660-11	708	3076	902	2428	712	48	11.00
PIM-660-12	770	3356	984	2649	776	52	12.00
PIM-660-13	831	3636	1066	2869	841	56	13.00
PIM-660-14	892	3915	1147	3090	906	61	14.00
PIM-660-15	954	4195	1229	3311	970	65	15.00
PIM-660-16	1015	4474	1311	3532	1035	69	16.00
PIM-660-17	1076	4754	1393	3752	1100	73	17.00
PIM-660-18	1137	5034	1475	3973	1164	78	18.00
PIM-660-19	1199	5313	1557	4194	1229	82	19.00
PIM-660-20	1260	5593	1639	4414	1294	86	20.00
PIM-660-21	1321	5873	1721	4635	1358	91	21.00
PIM-660-22	1383	6152	1803	4856	1423	95	22.00
PIM-660-23	1444	6432	1885	5077	1488	99	23.00
PIM-660-24	1505	6712	1967	5297	1553	104	24.00
PIM-660-25	1567	6991	2049	5518	1617	108	25.00
PIM-660-26	1628	7271	2131	5739	1682	112	26.00
PIM-660-27	1689	7551	2213	5960	1747	117	27.00
PIM-660-28	1750	7830	2295	6180	1811	121	28.00
PIM-660-29	1812	8110	2377	6401	1876	125	29.00
PIM-660-30	1873	8390	2459	6622	1941	130	30.00
PIM-660-31	1934	8669	2541	6842	2005	134	31.00
PIM-660-32	1996	8949	2623	7063	2070	138	32.00
PIM-660-33	2057	9229	2705	7284	2135	143	33.00
PIM-660-34	2118	9508	2787	7505	2199	147	34.00
PIM-660-35	2180	9788	2869	7725	2264	151	35.00
PIM-660-36	2241	10068	2951	7946	2329	156	36.00
PIM-660-37	2302	10347	3033	8167	2394	160	37.00
PIM-660-38	2363	10627	3115	8387	2458	164	38.00
PIM-660-39	2425	10907	3197	8608	2523	169	39.00
PIM-660-40	2486	11186	3278	8829	2588	173	40.00

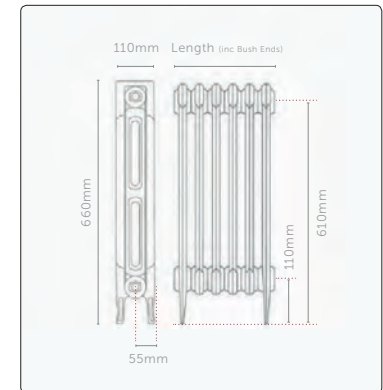
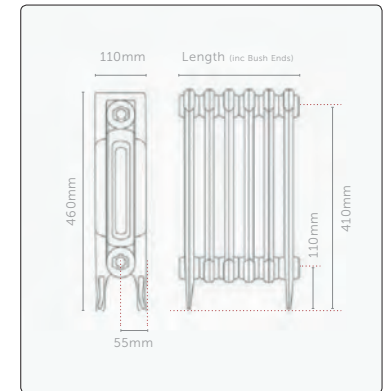

Dt50 figures shown in accordance with BS EN442. We have, from experience, found that the Dt60 figures usually give adequate output without oversizing the radiators on standard heating systems. Maximum test pressure = 3.3 bar | Maximum working pressure = 2.5 bar. Lengths quoted are given in good faith. However, due to the nature of the manufacturing process tolerances can and should be expected. Quoted dimensions should therefore only be used as a guideline. Longer lengths are available on request.

760 mm

CODE/ SECTIONS	LENGTH	OUTPUT				WEIGHT (KG)	WATER CONTENT (LTRs)
		Dt60		Dt50			
		BTUs	WATTS	BTUs	WATTS		
PIM-760-03	220	967	283	763	224	15	3.30
PIM-760-04	282	1289	378	1017	298	20	4.40
PIM-760-05	344	1611	472	1272	373	25	5.50
PIM-760-06	405	1933	567	1526	447	31	6.60
PIM-760-07	467	2256	661	1780	522	36	7.70
PIM-760-08	529	2578	756	2035	596	41	8.80
PIM-760-09	591	2900	850	2289	671	46	9.90
PIM-760-10	653	3222	944	2543	745	51	11.00
PIM-760-11	715	3545	1039	2798	820	56	12.10
PIM-760-12	777	3867	1133	3052	894	61	13.20
PIM-760-13	839	4189	1228	3306	969	66	14.30
PIM-760-14	901	4511	1322	3561	1044	71	15.40
PIM-760-15	963	4834	1417	3815	1118	76	16.50
PIM-760-16	1024	5156	1511	4069	1193	81	17.60
PIM-760-17	1086	5478	1606	4324	1267	86	18.70
PIM-760-18	1148	5800	1700	4578	1342	91	19.80
PIM-760-19	1210	6122	1794	4832	1416	97	20.90
PIM-760-20	1272	6445	1889	5087	1491	102	22.00
PIM-760-21	1334	6767	1983	5341	1565	107	23.10
PIM-760-22	1396	7089	2078	5595	1640	112	24.20
PIM-760-23	1458	7411	2172	5850	1714	117	25.30
PIM-760-24	1520	7734	2267	6104	1789	122	26.40
PIM-760-25	1582	8056	2361	6358	1864	127	27.50
PIM-760-26	1643	8378	2455	6613	1938	132	28.60
PIM-760-27	1705	8700	2550	6867	2013	137	29.70
PIM-760-28	1767	9023	2644	7121	2087	142	30.80
PIM-760-29	1829	9345	2739	7376	2162	147	31.90
PIM-760-30	1891	9667	2833	7630	2236	152	33.00
PIM-760-31	1953	9989	2928	7884	2311	158	34.10
PIM-760-32	2015	10312	3022	8139	2385	163	35.20
PIM-760-33	2077	10634	3117	8393	2460	168	36.30
PIM-760-34	2139	10956	3211	8647	2534	173	37.40
PIM-760-35	2201	11278	3305	8902	2609	178	38.50
PIM-760-36	2262	11601	3400	9156	2683	183	39.60
PIM-760-37	2324	11923	3494	9410	2758	188	40.70
PIM-760-38	2386	12245	3589	9665	2833	193	41.80
PIM-760-39	2448	12567	3683	9919	2907	198	42.90
PIM-760-40	2510	12889	3778	10173	2982	203	44.00

800 mm

CODE/ SECTIONS	LENGTH	OUTPUT				WEIGHT (KG)	WATER CONTENT (LTRs)
		Dt60		Dt50			
		BTUs	WATTS	BTUs	WATTS		
STP-800-03	217	1506	441	1189	348	43	5.25
STP-800-04	279	2008	589	1585	465	57	7.00
STP-800-05	340	2511	736	1982	581	71	8.75
STP-800-06	401	3013	883	2378	697	85	10.50
STP-800-07	462	3515	1030	2774	813	100	12.25
STP-800-08	523	4017	1177	3170	929	114	14.00
STP-800-09	584	4519	1324	3567	1045	128	15.75
STP-800-10	646	5021	1472	3963	1162	142	17.50
STP-800-11	707	5523	1619	4359	1278	156	19.25
STP-800-12	768	6025	1766	4756	1394	171	21.00
STP-800-13	829	6528	1913	5152	1510	185	22.75
STP-800-14	890	7030	2060	5548	1626	199	24.50
STP-800-15	951	7532	2207	5945	1742	213	26.25
STP-800-16	1012	8034	2355	6341	1858	228	28.00
STP-800-17	1074	8536	2502	6737	1975	242	29.75
STP-800-18	1135	9038	2649	7133	2091	256	31.50
STP-800-19	1196	9540	2796	7530	2207	270	33.25
STP-800-20	1257	10042	2943	7926	2323	284	35.00
STP-800-21	1318	10544	3090	8322	2439	299	36.75
STP-800-22	1379	11047	3238	8719	2555	313	38.50
STP-800-23	1440	11549	3385	9115	2671	327	40.25
STP-800-24	1502	12051	3532	9511	2788	341	42.00
STP-800-25	1563	12553	3679	9908	2904	356	43.75
STP-800-26	1624	13055	3826	10304	3020	370	45.50
STP-800-27	1685	13557	3973	10700	3136	384	47.25
STP-800-28	1746	14059	4121	11097	3252	398	49.00
STP-800-29	1807	14561	4268	11493	3368	412	50.75
STP-800-30	1869	15064	4415	11889	3485	427	52.50
STP-800-31	1930	15566	4562	12285	3601	441	54.25
STP-800-32	1991	16068	4709	12682	3717	455	56.00
STP-800-33	2052	16570	4856	13078	3833	469	57.75
STP-800-34	2113	17072	5004	13474	3949	484	59.50
STP-800-35	2174	17574	5151	13871	4065	498	61.25
STP-800-36	2235	18076	5298	14267	4181	512	63.00
STP-800-37	2297	18578	5445	14663	4298	526	64.75
STP-800-38	2358	19080	5592	15060	4414	540	66.50
STP-800-39	2419	19583	5739	15456	4530	555	68.25
STP-800-40	2480	20085	5886	15852	4646	569	70.00

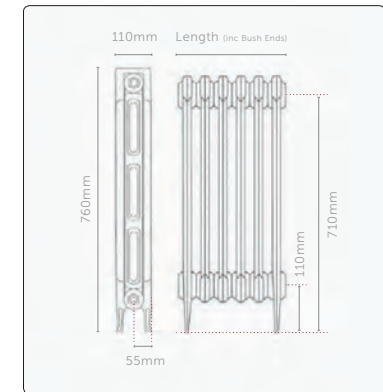

Saint Paul

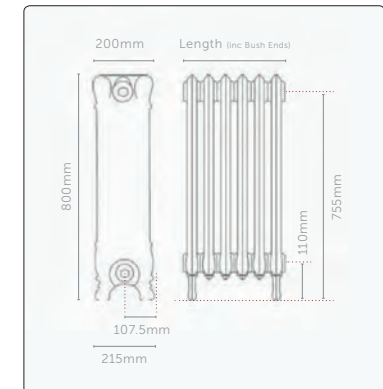

Dt50 figures shown in accordance with BS EN442. We have, from experience, found that the Dt60 figures usually give adequate output without oversizing the radiators on standard heating systems. Maximum test pressure = 3.3 bar | Maximum working pressure = 2.5 bar. Lengths quoted are given in good faith. However, due to the nature of the manufacturing process tolerances can and should be expected. Quoted dimensions should therefore only be used as a guideline. Longer lengths are available on request.

540 mm

CODE/ SECTIONS	LENGTH	OUTPUT				WEIGHT (KG)	WATER CONTENT (LTRs)
		Dt60		Dt50			
		BTUs	WATTS	BTUs	WATTS		
SHAF-540-03	313	1045	306	825	242	21	3.60
SHAF-540-04	406	1394	408	1100	322	28	4.80
SHAF-540-05	499	1742	511	1375	403	36	6.00
SHAF-540-06	591	2091	613	1650	484	43	7.20
SHAF-540-07	684	2439	715	1925	564	50	8.40
SHAF-540-08	777	2787	817	2200	645	57	9.60
SHAF-540-09	870	3136	919	2475	725	64	10.80
SHAF-540-10	963	3484	1021	2750	806	71	12.00
SHAF-540-11	1056	3833	1123	3025	887	78	13.20
SHAF-540-12	1149	4181	1225	3300	967	85	14.40
SHAF-540-13	1242	4530	1328	3575	1048	92	15.60
SHAF-540-14	1335	4878	1430	3850	1128	99	16.80
SHAF-540-15	1428	5227	1532	4125	1209	107	18.00
SHAF-540-16	1520	5575	1634	4400	1290	114	19.20
SHAF-540-17	1613	5923	1736	4675	1370	121	20.40
SHAF-540-18	1706	6272	1838	4950	1451	128	21.60
SHAF-540-19	1799	6620	1940	5225	1531	135	22.80
SHAF-540-20	1892	6969	2042	5500	1612	142	24.00
SHAF-540-21	1985	7317	2145	5775	1693	149	25.20
SHAF-540-22	2078	7666	2247	6050	1773	156	26.40
SHAF-540-23	2171	8014	2349	6325	1854	163	27.60
SHAF-540-24	2264	8362	2451	6600	1934	170	28.80
SHAF-540-25	2357	8711	2553	6875	2015	178	30.00
SHAF-540-26	2449	9059	2655	7150	2096	185	31.20
SHAF-540-27	2542	9408	2757	7425	2176	192	32.40
SHAF-540-28	2635	9756	2859	7700	2257	199	33.60
SHAF-540-29	2728	10105	2961	7975	2337	206	34.80
SHAF-540-30	2821	10453	3064	8250	2418	213	36.00
SHAF-540-31	2914	10801	3166	8525	2499	220	37.20
SHAF-540-32	3007	11150	3268	8800	2579	227	38.40
SHAF-540-33	3100	11498	3370	9075	2660	234	39.60
SHAF-540-34	3193	11847	3472	9350	2740	241	40.80
SHAF-540-35	3286	12195	3574	9625	2821	249	42.00
SHAF-540-36	3378	12544	3676	9900	2902	256	43.20
SHAF-540-37	3471	12892	3778	10175	2982	263	44.40
SHAF-540-38	3564	13240	3881	10450	3063	270	45.60
SHAF-540-39	3657	13589	3983	10725	3143	277	46.80
SHAF-540-40	3750	13937	4085	11000	3224	284	48.00

740 mm

CODE/ SECTIONS	LENGTH	OUTPUT				WEIGHT (KG)	WATER CONTENT (LTRs)
		Dt60		Dt50			
		BTUs	WATTS	BTUs	WATTS		
SHAF-740-03	313	1441	422	1137	333	28	4.50
SHAF-740-04	406	1921	563	1516	444	38	6.00
SHAF-740-05	499	2401	704	1895	556	47	7.50
SHAF-740-06	591	2882	845	2274	667	57	9.00
SHAF-740-07	684	3362	985	2654	778	66	10.50
SHAF-740-08	777	3842	1126	3033	889	76	12.00
SHAF-740-09	870	4323	1267	3412	1000	85	13.50
SHAF-740-10	963	4803	1408	3791	1111	94	15.00
SHAF-740-11	1056	5283	1548	4170	1222	104	16.50
SHAF-740-12	1149	5763	1689	4549	1333	113	18.00
SHAF-740-13	1242	6244	1830	4928	1444	123	19.50
SHAF-740-14	1335	6724	1971	5307	1555	132	21.00
SHAF-740-15	1428	7204	2111	5686	1667	142	22.50
SHAF-740-16	1520	7685	2252	6065	1778	151	24.00
SHAF-740-17	1613	8165	2393	6444	1889	161	25.50
SHAF-740-18	1706	8645	2534	6823	2000	170	27.00
SHAF-740-19	1799	9125	2675	7202	2111	179	28.50
SHAF-740-20	1892	9606	2815	7581	2222	189	30.00
SHAF-740-21	1985	10086	2956	7961	2333	198	31.50
SHAF-740-22	2078	10566	3097	8340	2444	208	33.00
SHAF-740-23	2171	11047	3238	8719	2555	217	34.50
SHAF-740-24	2264	11527	3378	9098	2666	227	36.00
SHAF-740-25	2357	12007	3519	9477	2777	236	37.50
SHAF-740-26	2449	12487	3660	9856	2889	245	39.00
SHAF-740-27	2542	12968	3801	10235	3000	255	40.50
SHAF-740-28	2635	13448	3941	10614	3111	264	42.00
SHAF-740-29	2728	13928	4082	10993	3222	274	43.50
SHAF-740-30	2821	14409	4223	11372	3333	283	45.00
SHAF-740-31	2914	14889	4364	11751	3444	293	46.50
SHAF-740-32	3007	15369	4504	12130	3555	302	48.00
SHAF-740-33	3100	15849	4645	12509	3666	312	49.50
SHAF-740-34	3193	16330	4786	12888	3777	321	51.00
SHAF-740-35	3286	16810	4927	13268	3889	330	52.50
SHAF-740-36	3378	17290	5067	13647	4000	340	54.00
SHAF-740-37	3471	17771	5208	14026	4111	349	55.50
SHAF-740-38	3564	18251	5349	14405	4222	359	57.00
SHAF-740-39	3657	18731	5490	14784	4333	368	58.50
SHAF-740-40	3750	19211	5631	15163	4444	378	60.00

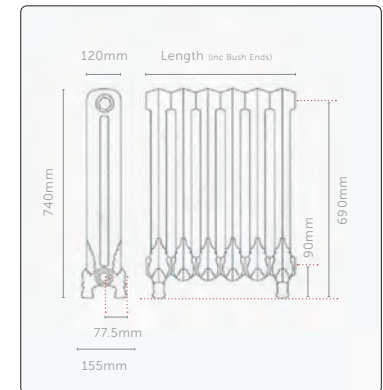
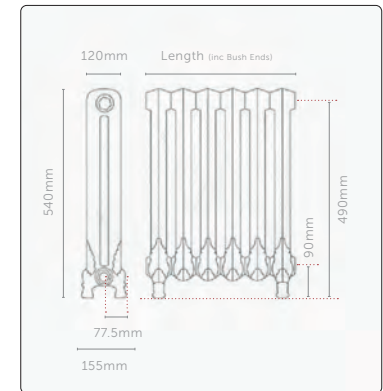

Dt50 figures shown in accordance with BS EN442. We have, from experience, found that the Dt60 figures usually give adequate output without oversizing the radiators on standard heating systems. Maximum test pressure = 3.3 bar | Maximum working pressure = 2.5 bar. Lengths quoted are given in good faith. However, due to the nature of the manufacturing process tolerances can and should be expected. Quoted dimensions should therefore only be used as a guideline. Longer lengths are available on request.

450 mm

CODE/ SECTIONS	LENGTH	OUTPUT				WEIGHT (KG)	WATER CONTENT (LTRs)
		Dt60		Dt50			
		BTUs	WATTS	BTUs	WATTS		
SLO-450-03	267	706	207	557	163	14	3.00
SLO-450-04	344	941	276	742	218	19	4.00
SLO-450-05	422	1176	345	928	272	24	5.00
SLO-450-06	500	1411	414	1114	326	29	6.00
SLO-450-07	577	1646	482	1299	381	33	7.00
SLO-450-08	655	1881	551	1485	435	38	8.00
SLO-450-09	732	2117	620	1671	490	43	9.00
SLO-450-10	810	2352	689	1856	544	48	10.00
SLO-450-11	888	2587	758	2042	598	52	11.00
SLO-450-12	965	2822	827	2227	653	57	12.00
SLO-450-13	1043	3057	896	2413	707	62	13.00
SLO-450-14	1120	3292	965	2599	762	67	14.00
SLO-450-15	1198	3528	1034	2784	816	71	15.00
SLO-450-16	1276	3763	1103	2970	870	76	16.00
SLO-450-17	1353	3998	1172	3155	925	81	17.00
SLO-450-18	1431	4233	1241	3341	979	86	18.00
SLO-450-19	1508	4468	1310	3527	1034	90	19.00
SLO-450-20	1586	4703	1378	3712	1088	95	20.00
SLO-450-21	1664	4939	1447	3898	1142	100	21.00
SLO-450-22	1741	5174	1516	4083	1197	105	22.00
SLO-450-23	1819	5409	1585	4269	1251	110	23.00
SLO-450-24	1896	5644	1654	4455	1306	114	24.00
SLO-450-25	1974	5879	1723	4640	1360	119	25.00
SLO-450-26	2052	6114	1792	4826	1414	124	26.00
SLO-450-27	2129	6350	1861	5012	1469	129	27.00
SLO-450-28	2207	6585	1930	5197	1523	133	28.00
SLO-450-29	2284	6820	1999	5383	1578	138	29.00
SLO-450-30	2362	7055	2068	5568	1632	143	30.00
SLO-450-31	2440	7290	2137	5754	1686	148	31.00
SLO-450-32	2517	7525	2206	5940	1741	152	32.00
SLO-450-33	2595	7761	2275	6125	1795	157	33.00
SLO-450-34	2672	7996	2343	6311	1850	162	34.00
SLO-450-35	2750	8231	2412	6496	1904	167	35.00
SLO-450-36	2828	8466	2481	6682	1958	171	36.00
SLO-450-37	2905	8701	2550	6868	2013	176	37.00
SLO-450-38	2983	8937	2619	7053	2067	181	38.00
SLO-450-39	3060	9172	2688	7239	2122	186	39.00
SLO-450-40	3138	9407	2757	7425	2176	190	40.00

750 mm

CODE/ SECTIONS	LENGTH	OUTPUT				WEIGHT (KG)	WATER CONTENT (LTRs)
		Dt60		Dt50			
		BTUs	WATTS	BTUs	WATTS		
SLO-750-03	264	1152	338	909	266	28	5.10
SLO-750-04	340	1536	450	1212	355	37	6.80
SLO-750-05	417	1919	563	1515	444	47	8.50
SLO-750-06	494	2303	675	1818	533	56	10.20
SLO-750-07	570	2687	788	2121	622	66	11.90
SLO-750-08	647	3071	900	2424	710	75	13.60
SLO-750-09	723	3455	1013	2727	799	84	15.30
SLO-750-10	800	3839	1125	3030	888	94	17.00
SLO-750-11	877	4223	1238	3333	977	103	18.70
SLO-750-12	953	4607	1350	3636	1066	112	20.40
SLO-750-13	1030	4990	1463	3939	1154	122	22.10
SLO-750-14	1106	5374	1575	4242	1243	131	23.80
SLO-750-15	1183	5758	1688	4545	1332	140	25.50
SLO-750-16	1260	6142	1800	4848	1421	150	27.20
SLO-750-17	1336	6526	1913	5151	1510	159	28.90
SLO-750-18	1413	6910	2025	5454	1598	169	30.60
SLO-750-19	1489	7294	2138	5757	1687	178	32.30
SLO-750-20	1566	7678	2250	6060	1776	187	34.00
SLO-750-21	1643	8062	2363	6363	1865	197	35.70
SLO-750-22	1719	8445	2475	6666	1954	206	37.40
SLO-750-23	1796	8829	2588	6969	2042	215	39.10
SLO-750-24	1872	9213	2700	7272	2131	225	40.80
SLO-750-25	1949	9597	2813	7575	2220	234	42.50
SLO-750-26	2026	9981	2925	7878	2309	243	44.20
SLO-750-27	2102	10365	3038	8181	2398	253	45.90
SLO-750-28	2179	10749	3150	8484	2486	262	47.60
SLO-750-29	2255	11133	3263	8787	2575	271	49.30
SLO-750-30	2332	11516	3375	9090	2664	281	51.00
SLO-750-31	2409	11900	3488	9393	2753	290	52.70
SLO-750-32	2485	12284	3600	9696	2842	300	54.40
SLO-750-33	2562	12668	3713	9999	2930	309	56.10
SLO-750-34	2638	13052	3825	10302	3019	318	57.80
SLO-750-35	2715	13436	3938	10604	3108	328	59.50
SLO-750-36	2792	13820	4050	10907	3197	337	61.20
SLO-750-37	2868	14204	4163	11210	3286	346	62.90
SLO-750-38	2945	14588	4275	11513	3374	356	64.60
SLO-750-39	3021	14971	4388	11816	3463	365	66.30
SLO-750-40	3098	15355	4500	12119	3552	374	68.00

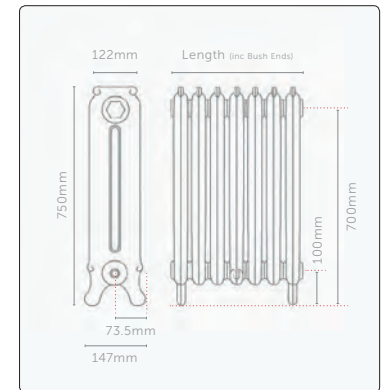
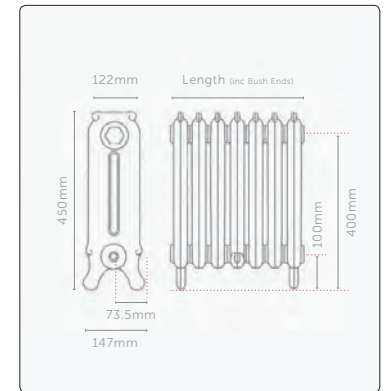

Dt50 figures shown in accordance with BS EN442. We have, from experience, found that the Dt60 figures usually give adequate output without oversizing the radiators on standard heating systems. Maximum test pressure = 3.3 bar | Maximum working pressure = 2.5 bar. Lengths quoted are given in good faith. However, due to the nature of the manufacturing process tolerances can and should be expected. Quoted dimensions should therefore only be used as a guideline. Longer lengths are available on request.

450 mm

CODE/ SECTIONS	LENGTH	OUTPUT				WEIGHT (KG)	WATER CONTENT (LTRs)
		Dt60		Dt50			
		BTUs	WATTS	BTUs	WATTS		
VIC3-450-03	215	652	191	515	151	10	1.65
VIC3-450-04	275	870	255	686	201	13	2.20
VIC3-450-05	335	1087	319	858	252	16	2.75
VIC3-450-06	395	1305	382	1030	302	19	3.30
VIC3-450-07	455	1522	446	1201	352	22	3.85
VIC3-450-08	516	1740	510	1373	402	25	4.40
VIC3-450-09	576	1957	574	1545	453	29	4.95
VIC3-450-10	636	2174	637	1716	503	32	5.50
VIC3-450-11	696	2392	701	1888	553	35	6.05
VIC3-450-12	756	2609	765	2059	604	38	6.60
VIC3-450-13	817	2827	828	2231	654	41	7.15
VIC3-450-14	877	3044	892	2403	704	45	7.70
VIC3-450-15	937	3262	956	2574	755	48	8.25
VIC3-450-16	997	3479	1020	2746	805	51	8.80
VIC3-450-17	1057	3697	1083	2918	855	54	9.35
VIC3-450-18	1118	3914	1147	3089	905	57	9.90
VIC3-450-19	1178	4131	1211	3261	956	60	10.45
VIC3-450-20	1238	4349	1275	3432	1006	64	11.00
VIC3-450-21	1298	4566	1338	3604	1056	67	11.55
VIC3-450-22	1358	4784	1402	3776	1107	70	12.10
VIC3-450-23	1419	5001	1466	3947	1157	73	12.65
VIC3-450-24	1479	5219	1530	4119	1207	76	13.20
VIC3-450-25	1539	5436	1593	4291	1258	80	13.75
VIC3-450-26	1599	5654	1657	4462	1308	83	14.30
VIC3-450-27	1659	5871	1721	4634	1358	86	14.85
VIC3-450-28	1720	6089	1784	4805	1408	89	15.40
VIC3-450-29	1780	6306	1848	4977	1459	92	15.95
VIC3-450-30	1840	6523	1912	5149	1509	95	16.50
VIC3-450-31	1900	6741	1976	5320	1559	99	17.05
VIC3-450-32	1960	6958	2039	5492	1610	102	17.60
VIC3-450-33	2021	7176	2103	5664	1660	105	18.15
VIC3-450-34	2081	7393	2167	5835	1710	108	18.70
VIC3-450-35	2141	7611	2231	6007	1761	111	19.25
VIC3-450-36	2201	7828	2294	6178	1811	115	19.80
VIC3-450-37	2261	8046	2358	6350	1861	118	20.35
VIC3-450-38	2322	8263	2422	6522	1911	121	20.90
VIC3-450-39	2382	8480	2485	6693	1962	124	21.45
VIC3-450-40	2442	8698	2549	6865	2012	127	22.00

645 mm

CODE/ SECTIONS	LENGTH	OUTPUT				WEIGHT (KG)	WATER CONTENT (LTRs)
		Dt60		Dt50			
		BTUs	WATTS	BTUs	WATTS		
VIC3-645-03	215	983	288	776	227	14	2.85
VIC3-645-04	276	1311	384	1035	303	19	3.80
VIC3-645-05	336	1638	480	1293	379	23	4.75
VIC3-645-06	396	1966	576	1552	455	28	5.70
VIC3-645-07	457	2294	672	1810	531	33	6.65
VIC3-645-08	517	2621	768	2069	606	37	7.60
VIC3-645-09	578	2949	864	2328	682	42	8.55
VIC3-645-10	638	3277	960	2586	758	47	9.50
VIC3-645-11	698	3605	1056	2845	834	51	10.45
VIC3-645-12	759	3932	1152	3104	910	56	11.40
VIC3-645-13	819	4260	1249	3362	985	61	12.35
VIC3-645-14	880	4588	1345	3621	1061	65	13.30
VIC3-645-15	940	4915	1441	3879	1137	70	14.25
VIC3-645-16	1000	5243	1537	4138	1213	75	15.20
VIC3-645-17	1061	5571	1633	4397	1289	79	16.15
VIC3-645-18	1121	5898	1729	4655	1364	84	17.10
VIC3-645-19	1182	6226	1825	4914	1440	89	18.05
VIC3-645-20	1242	6554	1921	5173	1516	93	19.00
VIC3-645-21	1302	6881	2017	5431	1592	98	19.95
VIC3-645-22	1363	7209	2113	5690	1668	103	20.90
VIC3-645-23	1423	7537	2209	5948	1743	107	21.85
VIC3-645-24	1484	7864	2305	6207	1819	112	22.80
VIC3-645-25	1544	8192	2401	6466	1895	117	23.75
VIC3-645-26	1604	8520	2497	6724	1971	121	24.70
VIC3-645-27	1665	8847	2593	6983	2047	126	25.65
VIC3-645-28	1725	9175	2689	7242	2122	131	26.60
VIC3-645-29	1786	9503	2785	7500	2198	135	27.55
VIC3-645-30	1846	9831	2881	7759	2274	140	28.50
VIC3-645-31	1906	10158	2977	8018	2350	145	29.45
VIC3-645-32	1967	10486	3073	8276	2426	149	30.40
VIC3-645-33	2027	10814	3169	8535	2501	154	31.35
VIC3-645-34	2088	11141	3265	8793	2577	158	32.30
VIC3-645-35	2148	11469	3361	9052	2653	163	33.25
VIC3-645-36	2208	11797	3457	9311	2729	168	34.20
VIC3-645-37	2269	12124	3553	9569	2805	172	35.15
VIC3-645-38	2329	12452	3649	9828	2880	177	36.10
VIC3-645-39	2390	12780	3746	10087	2956	182	37.05
VIC3-645-40	2450	13107	3842	10345	3032	186	38.00

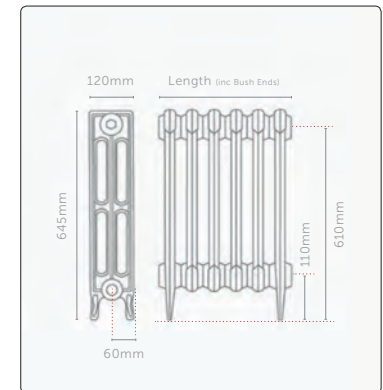
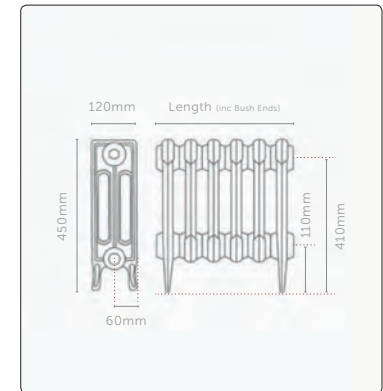

Dt50 figures shown in accordance with BS EN442. We have, from experience, found that the Dt60 figures usually give adequate output without oversizing the radiators on standard heating systems. Maximum test pressure = 3.3 bar | Maximum working pressure = 2.5 bar. Lengths quoted are given in good faith. However, due to the nature of the manufacturing process tolerances can and should be expected. Quoted dimensions should therefore only be used as a guideline. Longer lengths are available on request.

Technical Data – Victoriana 3 column

745 mm

CODE/ SECTIONS	LENGTH	OUTPUT				WEIGHT (KG)	WATER CONTENT (LTRs)
		Dt60		Dt50			
		BTUs	WATTS	BTUs	WATTS		
VIC3-745-03	218	1119	328	883	259	17	3.00
VIC3-745-04	280	1492	437	1178	345	22	4.00
VIC3-745-05	341	1865	547	1472	432	28	5.00
VIC3-745-06	402	2238	656	1767	518	34	6.00
VIC3-745-07	464	2612	765	2061	604	39	7.00
VIC3-745-08	525	2985	875	2356	690	45	8.00
VIC3-745-09	587	3358	984	2650	777	50	9.00
VIC3-745-10	648	3731	1093	2945	863	56	10.00
VIC3-745-11	709	4104	1203	3239	949	62	11.00
VIC3-745-12	771	4477	1312	3533	1036	67	12.00
VIC3-745-13	832	4850	1421	3828	1122	73	13.00
VIC3-745-14	894	5223	1531	4122	1208	78	14.00
VIC3-745-15	955	5596	1640	4417	1295	84	15.00
VIC3-745-16	1016	5969	1749	4711	1381	90	16.00
VIC3-745-17	1078	6342	1859	5006	1467	95	17.00
VIC3-745-18	1139	6715	1968	5300	1553	101	18.00
VIC3-745-19	1201	7088	2077	5595	1640	106	19.00
VIC3-745-20	1262	7462	2187	5889	1726	112	20.00
VIC3-745-21	1323	7835	2296	6184	1812	118	21.00
VIC3-745-22	1385	8208	2406	6478	1899	123	22.00
VIC3-745-23	1446	8581	2515	6772	1985	129	23.00
VIC3-745-24	1508	8954	2624	7067	2071	134	24.00
VIC3-745-25	1569	9327	2734	7361	2158	140	25.00
VIC3-745-26	1630	9700	2843	7656	2244	146	26.00
VIC3-745-27	1692	10073	2952	7950	2330	151	27.00
VIC3-745-28	1753	10446	3062	8245	2416	157	28.00
VIC3-745-29	1815	10819	3171	8539	2503	162	29.00
VIC3-745-30	1876	11192	3280	8834	2589	168	30.00
VIC3-745-31	1937	11565	3390	9128	2675	174	31.00
VIC3-745-32	1999	11938	3499	9423	2762	179	32.00
VIC3-745-33	2060	12311	3608	9717	2848	185	33.00
VIC3-745-34	2122	12685	3718	10011	2934	190	34.00
VIC3-745-35	2183	13058	3827	10306	3021	196	35.00
VIC3-745-36	2244	13431	3936	10600	3107	202	36.00
VIC3-745-37	2306	13804	4046	10895	3193	207	37.00
VIC3-745-38	2367	14177	4155	11189	3279	213	38.00
VIC3-745-39	2429	14550	4264	11484	3366	218	39.00
VIC3-745-40	2490	14923	4374	11778	3452	224	40.00

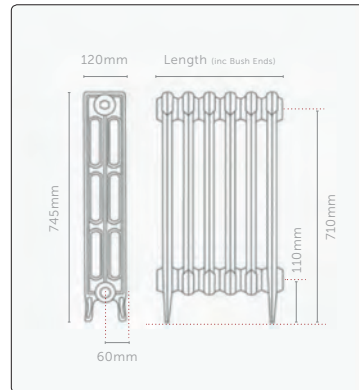

Dt50 figures shown in accordance with BS EN442. We have, from experience, found that the Dt60 figures usually give adequate output without oversizing the radiators on standard heating systems. Maximum test pressure = 3.3 bar | Maximum working pressure = 2.5 bar. Lengths quoted are given in good faith. However, due to the nature of the manufacturing process tolerances can and should be expected. Quoted dimensions should therefore only be used as a guideline. Longer lengths are available on request.

460 mm

CODE/ SECTIONS	LENGTH	OUTPUT				WEIGHT (KG)	WATER CONTENT (LTRs)
		Dt60		Dt50			
		BTUs	WATTS	BTUs	WATTS		
VIC4-460-03	216	730	214	576	169	10	1.50
VIC4-460-04	277	974	285	768	225	13	2.00
VIC4-460-05	338	1217	357	960	282	16	2.50
VIC4-460-06	398	1460	428	1153	338	20	3.00
VIC4-460-07	459	1704	499	1345	394	23	3.50
VIC4-460-08	520	1947	571	1537	450	26	4.00
VIC4-460-09	580	2190	642	1729	507	30	4.50
VIC4-460-10	641	2434	713	1921	563	33	5.00
VIC4-460-11	702	2677	785	2113	619	36	5.50
VIC4-460-12	762	2921	856	2305	676	39	6.00
VIC4-460-13	823	3164	927	2497	732	43	6.50
VIC4-460-14	884	3407	999	2689	788	46	7.00
VIC4-460-15	945	3651	1070	2881	845	49	7.50
VIC4-460-16	1005	3894	1141	3074	901	53	8.00
VIC4-460-17	1066	4138	1213	3266	957	56	8.50
VIC4-460-18	1127	4381	1284	3458	1013	59	9.00
VIC4-460-19	1187	4624	1355	3650	1070	62	9.50
VIC4-460-20	1248	4868	1427	3842	1126	66	10.00
VIC4-460-21	1309	5111	1498	4034	1182	69	10.50
VIC4-460-22	1369	5354	1569	4226	1239	72	11.00
VIC4-460-23	1430	5598	1641	4418	1295	75	11.50
VIC4-460-24	1491	5841	1712	4610	1351	79	12.00
VIC4-460-25	1552	6085	1783	4802	1408	82	12.50
VIC4-460-26	1612	6328	1855	4994	1464	85	13.00
VIC4-460-27	1673	6571	1926	5187	1520	89	13.50
VIC4-460-28	1734	6815	1997	5379	1576	92	14.00
VIC4-460-29	1794	7058	2069	5571	1633	95	14.50
VIC4-460-30	1855	7302	2140	5763	1689	98	15.00
VIC4-460-31	1916	7545	2211	5955	1745	102	15.50
VIC4-460-32	1976	7788	2283	6147	1802	105	16.00
VIC4-460-33	2037	8032	2354	6339	1858	108	16.50
VIC4-460-34	2098	8275	2425	6531	1914	112	17.00
VIC4-460-35	2159	8518	2497	6723	1971	115	17.50
VIC4-460-36	2219	8762	2568	6915	2027	118	18.00
VIC4-460-37	2280	9005	2639	7108	2083	121	18.50
VIC4-460-38	2341	9249	2711	7300	2139	125	19.00
VIC4-460-39	2401	9492	2782	7492	2196	128	19.50
VIC4-460-40	2462	9735	2853	7684	2252	131	20.00

660 mm

CODE/ SECTIONS	LENGTH	OUTPUT				WEIGHT (KG)	WATER CONTENT (LTRs)
		Dt60		Dt50			
		BTUs	WATTS	BTUs	WATTS		
VIC4-660-03	219	1053	309	831	244	13	1.88
VIC4-660-04	281	1404	412	1108	325	18	2.50
VIC4-660-05	343	1755	514	1385	406	22	3.13
VIC4-660-06	405	2106	617	1662	487	26	3.75
VIC4-660-07	467	2457	720	1939	568	31	4.38
VIC4-660-08	528	2808	823	2216	650	35	5.00
VIC4-660-09	590	3159	926	2493	731	40	5.63
VIC4-660-10	652	3510	1029	2771	812	44	6.25
VIC4-660-11	714	3861	1132	3048	893	48	6.88
VIC4-660-12	776	4212	1235	3325	974	53	7.50
VIC4-660-13	837	4563	1337	3602	1056	57	8.13
VIC4-660-14	899	4914	1440	3879	1137	62	8.75
VIC4-660-15	961	5265	1543	4156	1218	66	9.38
VIC4-660-16	1023	5616	1646	4433	1299	70	10.00
VIC4-660-17	1085	5967	1749	4710	1380	75	10.63
VIC4-660-18	1146	6319	1852	4987	1462	79	11.25
VIC4-660-19	1208	6670	1955	5264	1543	84	11.88
VIC4-660-20	1270	7021	2058	5541	1624	88	12.50
VIC4-660-21	1332	7372	2160	5818	1705	92	13.13
VIC4-660-22	1394	7723	2263	6095	1786	97	13.75
VIC4-660-23	1455	8074	2366	6372	1868	101	14.38
VIC4-660-24	1517	8425	2469	6649	1949	106	15.00
VIC4-660-25	1579	8776	2572	6926	2030	110	15.63
VIC4-660-26	1641	9127	2675	7203	2111	114	16.25
VIC4-660-27	1703	9478	2778	7480	2192	119	16.88
VIC4-660-28	1764	9829	2881	7758	2274	123	17.50
VIC4-660-29	1826	10180	2984	8035	2355	128	18.13
VIC4-660-30	1888	10531	3086	8312	2436	132	18.75
VIC4-660-31	1950	10882	3189	8589	2517	136	19.38
VIC4-660-32	2012	11233	3292	8866	2598	141	20.00
VIC4-660-33	2073	11584	3395	9143	2680	145	20.63
VIC4-660-34	2135	11935	3498	9420	2761	150	21.25
VIC4-660-35	2197	12286	3601	9697	2842	154	21.88
VIC4-660-36	2259	12637	3704	9974	2923	158	22.50
VIC4-660-37	2321	12988	3807	10251	3004	163	23.13
VIC4-660-38	2382	13339	3909	10528	3086	167	23.75
VIC4-660-39	2444	13690	4012	10805	3167	172	24.38
VIC4-660-40	2506	14041	4115	11082	3248	176	25.00

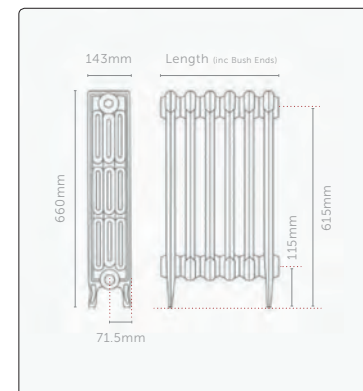
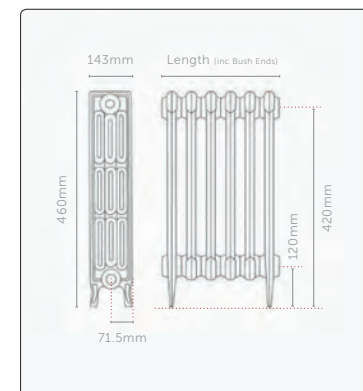

Dt50 figures shown in accordance with BS EN442. We have, from experience, found that the Dt60 figures usually give adequate output without oversizing the radiators on standard heating systems. Maximum test pressure = 3.3 bar | Maximum working pressure = 2.5 bar. Lengths quoted are given in good faith. However, due to the nature of the manufacturing process tolerances can and should be expected. Quoted dimensions should therefore only be used as a guideline. Longer lengths are available on request.

Technical Data – Victoriana 4 column

760 mm

CODE/ SECTIONS	LENGTH	OUTPUT				WEIGHT (KG)	WATER CONTENT (LTRs)
		Dt60		Dt50			
		BTUs	WATTS	BTUs	WATTS		
VIC4-760-03	217	1229	360	970	284	17	2.55
VIC4-760-04	278	1638	480	1293	379	23	3.40
VIC4-760-05	340	2048	600	1616	474	29	4.25
VIC4-760-06	401	2457	720	1939	568	35	5.10
VIC4-760-07	462	2867	840	2263	663	41	5.95
VIC4-760-08	523	3276	960	2586	758	46	6.80
VIC4-760-09	584	3686	1080	2909	853	52	7.65
VIC4-760-10	645	4095	1200	3232	947	58	8.50
VIC4-760-11	706	4505	1320	3555	1042	64	9.35
VIC4-760-12	767	4914	1440	3879	1137	70	10.20
VIC4-760-13	828	5324	1560	4202	1231	75	11.05
VIC4-760-14	889	5733	1680	4525	1326	81	11.90
VIC4-760-15	951	6143	1800	4848	1421	87	12.75
VIC4-760-16	1012	6552	1920	5172	1516	93	13.60
VIC4-760-17	1073	6962	2040	5495	1610	99	14.45
VIC4-760-18	1134	7371	2160	5818	1705	104	15.30
VIC4-760-19	1195	7781	2280	6141	1800	110	16.15
VIC4-760-20	1256	8190	2400	6464	1895	116	17.00
VIC4-760-21	1317	8600	2520	6788	1989	122	17.85
VIC4-760-22	1378	9009	2641	7111	2084	128	18.70
VIC4-760-23	1439	9419	2761	7434	2179	133	19.55
VIC4-760-24	1500	9828	2881	7757	2274	139	20.40
VIC4-760-25	1562	10238	3001	8080	2368	145	21.25
VIC4-760-26	1623	10647	3121	8404	2463	151	22.10
VIC4-760-27	1684	11057	3241	8727	2558	157	22.95
VIC4-760-28	1745	11467	3361	9050	2652	162	23.80
VIC4-760-29	1806	11876	3481	9373	2747	168	24.65
VIC4-760-30	1867	12286	3601	9697	2842	174	25.50
VIC4-760-31	1928	12695	3721	10020	2937	180	26.35
VIC4-760-32	1989	13105	3841	10343	3031	186	27.20
VIC4-760-33	2050	13514	3961	10666	3126	191	28.05
VIC4-760-34	2111	13924	4081	10989	3221	197	28.90
VIC4-760-35	2173	14333	4201	11313	3316	203	29.75
VIC4-760-36	2234	14743	4321	11636	3410	209	30.60
VIC4-760-37	2295	15152	4441	11959	3505	215	31.45
VIC4-760-38	2356	15562	4561	12282	3600	220	32.30
VIC4-760-39	2417	15971	4681	12606	3694	226	33.15
VIC4-760-40	2478	16381	4801	12929	3789	232	34.00

813 mm

CODE/ SECTIONS	LENGTH	OUTPUT				WEIGHT (KG)	WATER CONTENT (LTRs)
		Dt60		Dt50			
		BTUs	WATTS	BTUs	WATTS		
VIC4-813-03	214	1360	399	1074	315	19	2.70
VIC4-813-04	274	1814	532	1432	420	26	3.60
VIC4-813-05	335	2267	665	1790	525	32	4.50
VIC4-813-06	395	2721	797	2148	629	39	5.40
VIC4-813-07	455	3174	930	2505	734	45	6.30
VIC4-813-08	515	3628	1063	2863	839	52	7.20
VIC4-813-09	575	4081	1196	3221	944	58	8.10
VIC4-813-10	635	4535	1329	3579	1049	65	9.00
VIC4-813-11	695	4988	1462	3937	1154	71	9.90
VIC4-813-12	755	5442	1595	4295	1259	78	10.80
VIC4-813-13	815	5895	1728	4653	1364	84	11.70
VIC4-813-14	875	6349	1861	5011	1469	90	12.60
VIC4-813-15	936	6802	1994	5369	1574	97	13.50
VIC4-813-16	996	7256	2127	5727	1678	103	14.40
VIC4-813-17	1056	7709	2259	6085	1783	110	15.30
VIC4-813-18	1116	8163	2392	6443	1888	116	16.20
VIC4-813-19	1176	8616	2525	6800	1993	123	17.10
VIC4-813-20	1236	9070	2658	7158	2098	129	18.00
VIC4-813-21	1296	9523	2791	7516	2203	136	18.90
VIC4-813-22	1356	9977	2924	7874	2308	142	19.80
VIC4-813-23	1416	10430	3057	8232	2413	149	20.70
VIC4-813-24	1476	10884	3190	8590	2518	155	21.60
VIC4-813-25	1537	11337	3323	8948	2623	162	22.50
VIC4-813-26	1597	11791	3456	9306	2727	168	23.40
VIC4-813-27	1657	12244	3589	9664	2832	174	24.30
VIC4-813-28	1717	12698	3721	10022	2937	181	25.20
VIC4-813-29	1777	13151	3854	10380	3042	187	26.10
VIC4-813-30	1837	13604	3987	10738	3147	194	27.00
VIC4-813-31	1897	14058	4120	11095	3252	200	27.90
VIC4-813-32	1957	14511	4253	11453	3357	207	28.80
VIC4-813-33	2017	14965	4386	11811	3462	213	29.70
VIC4-813-34	2077	15418	4519	12169	3567	220	30.60
VIC4-813-35	2138	15872	4652	12527	3672	226	31.50
VIC4-813-36	2198	16325	4785	12885	3776	233	32.40
VIC4-813-37	2258	16779	4918	13243	3881	239	33.30
VIC4-813-38	2318	17232	5051	13601	3986	246	34.20
VIC4-813-39	2378	17686	5183	13959	4091	252	35.10
VIC4-813-40	2438	18139	5316	14317	4196	258	36.00

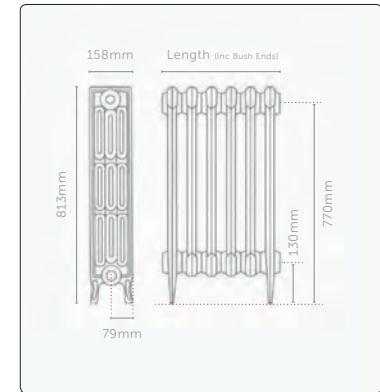
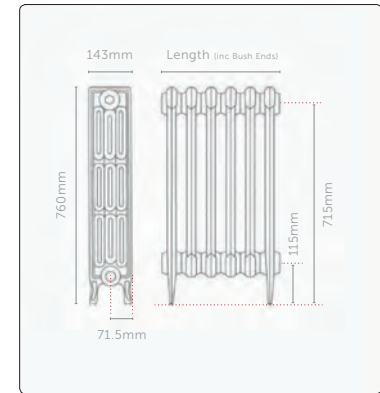

Dt50 figures shown in accordance with BS EN442. We have, from experience, found that the Dt60 figures usually give adequate output without oversizing the radiators on standard heating systems. Maximum test pressure = 3.3 bar | Maximum working pressure = 2.5 bar. Lengths quoted are given in good faith. However, due to the nature of the manufacturing process tolerances can and should be expected. Quoted dimensions should therefore only be used as a guideline. Longer lengths are available on request.

Further Information

THE PALADIN TEAM ARE ALWAYS ON HAND TO ANSWER ANY QUERIES YOU MAY HAVE. PLEASE DO NOT HESITATE TO CONTACT US.

Delivery Options

We know you can't wait to witness the magnificent beauty of your new cast iron radiators. And we don't keep you waiting. We can deliver your radiators in just 7 days (depending on the finish required).

How is my delivery organised?

When you place your order we will acknowledge your order and offer you an 'available from' delivery date which you can confirm from that date onwards on a day that best suits you. Deliveries are made on any day of the working week. Deliveries are made through the pallet network and delivered to the nearest accessible external hard standing. Their movement thereafter is over to your labour. It is possible to request morning or afternoon deliveries which are usually available in most areas but this does cost extra. Please also consider access issues for a large lorry (18 Tonnes) and if you think there may be access issues request the smaller lorry option of 7.5 Tonnes. Call us on 01205 280354 or email us to discuss and place your order.

How long does delivery take?

For our Paladin Colours metals range delivery is just 7 days. For all other Paint Effects it's 14 days and for Polished radiators it's 3-4 weeks.

Delivery

We offer a reliable UK kerbside delivery service through the UK Pallet Network, some remote geographical areas may incur additional charges. We also offer worldwide deliveries on an individually priced basis.

For T&C's please visit our website.

How will my radiators arrive?

Your cast iron radiators are delivered individually wrapped with each individual radiator layer separated with a thick card then secured flat onto the pallet(s). There is a length limit of 1200mm where the radiator would overhang the end of the pallet and in these instances the radiator is delivered in two or more pieces for re-assembly on site (by others), full instructions are provided. All Paladin radiators are fully pressure tested to 6 Bar ready for installation. Any valves or accessories are supplied loose. Call us on 01205 280354 to discuss your individual requirements.

Can I collect my Order?

If you would prefer to collect your cast iron radiators from us, then we can arrange for you collection from our workshops in Lincolnshire. An appointment is necessary before collection so we have your order prepped and ready to go.

What about worldwide delivery options?

We export hundreds of shipments per year of cast iron radiators all over the world, as far as Australia, New Zealand, America, and Europe. From Châteaux renovations, new builds, renovating period properties, castles and palaces, we have provided cast iron radiators for many exciting projects abroad which include projects for Royalty and Hollywood stars. We also have agencies operating in many countries that can help you on a more local basis.

Most shipments abroad are shipped by sea but smaller items can leave via international courier services. When ordering for abroad, once we know the size, weight and final destination of your order, the Paladin Sales Team will provide you with a shipping quotation and advise on a lead time for the delivery usually this is provided on a door to door service basis. We try and make your international delivery service as easy as possible. Call us on 01205 280354 or email us to discuss prices for your cast iron radiators and shipment options.





Sloane
Height 450 mm
Farrow & Ball – Wimborne White
Belgravia Brushed Nickel TRV Valve Set
Brushed Nickel Pipe Sleeve Kit



Victoriana 3
Height 745 mm
Farrow & Ball – Mahogany
Belgravia Brushed Nickel TRV Valve Set
Brushed Nickel Pipe Sleeve Kit



01205 280354

sales@paladinradiators.com

www.paladinradiators.com

Paladin Radiators
Langrick Road, New York
Lincolnshire LN4 4XH

